



WITHSTANDING THE WINDS OF TIME

Ever since the world's first iconic concrete structure was created, it has inspired the artworks of permanence and timeless, daring beauty. With every piece we create we try to follow the same principles of classical beauty; the beauty that is not subject to time, fashion or elements of nature.

CONNECTING LANDSCAPE AND ARCHITECTURE

Essentially every great urban project starts with the volumes of space that are transformed into iconic places of style, elegance and proportion. This can only be done if you look at it from different perspectives, such as people who use it, landscapes that surround it, and cultural context that it is immersed in. We are honored to leave Bellitalia®'s mark in over 30 countries and have our products installed in some of the world's most remarkable squares, parks, museums and university campuses.





MAKING ASYMMETRY AS GRACEFUL AS SYMMETRY

Asymmetry creates dramatic design statements.
It allows for differences and diversity to coexist within the same time and space.
Asymmetry is not constrained by the traditional laws of perfection
and is not subject to the classical rules of balance.
But we've learned that with the right combination
of style and skill it can be mastered.

From lightness and porcelain-like delicacy to raw unpretentious honesty of grey concrete - this mold-able material transforms itself to tell a story, as novel as design itself, to anyone willing to listen. By offering a greater choice of aggregates, materials, and finishes, we help to make each project truly unique and personal.

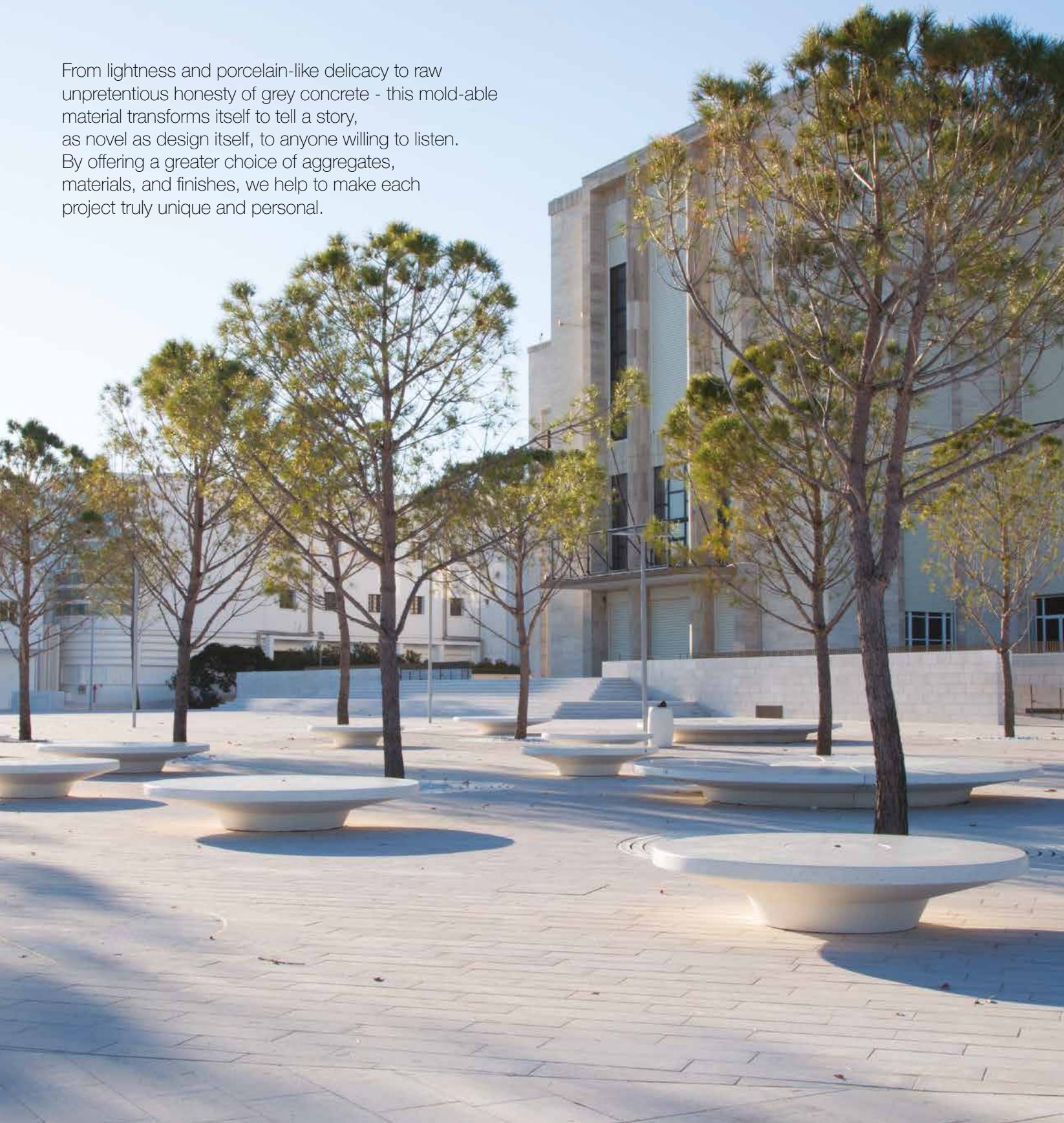

EMBRACING ARTISTIC EXPRESSION

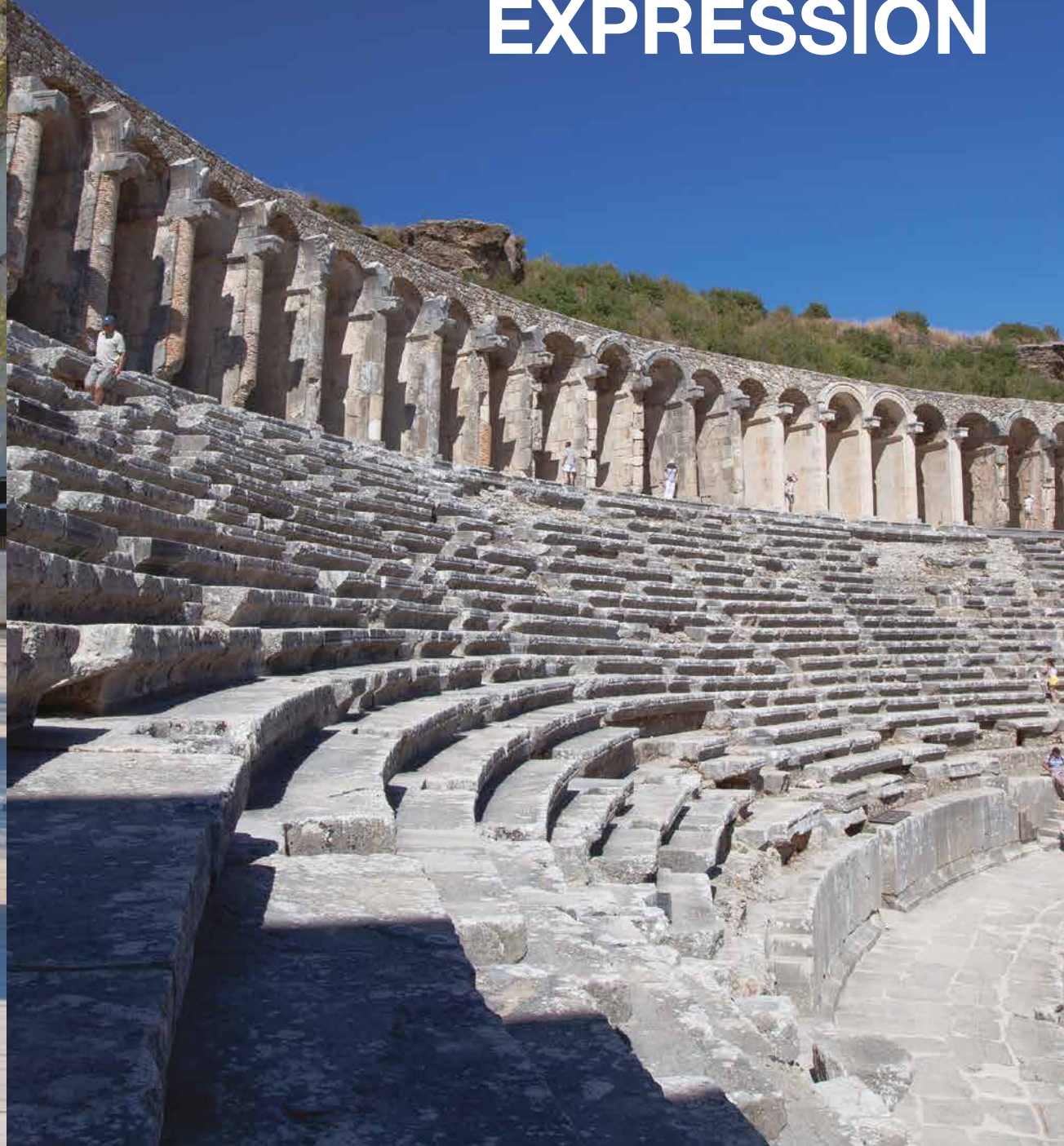



BREAKING THE MOLD. LITERALLY

We believe that by using technology in a creative way one can shape the architectural wonders of tomorrow. We also know that to do that, sometimes you have to break the mold: whether it means challenging the old ways or literally taking a mold and starting over. Believe us! We know. We've created over 500 of them.

When you take innovative manufacturing techniques and combine them with over 50 years of experience, you can go as far as challenging the laws of gravity.

Our formula of Ultratense Concrete® has helped to push urban design a step further allowing to create increasingly complex and more delicate, thinner forms.

GIVING WINGS TO CONCRETE IDEAS





STAYING “CLASSIC” IN A WORLD FULL OF TRENDS

When it comes to concrete urban furniture your biggest dilemma should be this - How do you make sure that the design will last as long as the product itself? While aesthetics change, classic never goes out of style. Being an Italian-born company, we are surrounded by pieces of art and architecture that have become timeless. We strive to design our products within the same canons of effortless beauty and classic design.



**INSPIRED BY
TIMELESS BEAUTY.**



Bellitalia® is the global manufacturer of concrete urban furniture and landscaping solutions. Numerous of company's products, designed around the fundamental principles of timeless beauty, exceptional quality and innovation of materials, have become iconic and can be found scattered throughout some of the most renowned piazzas, picturesque streets and city parks of the world.

Thanks to its versatility, strength and unmatched ability to combine function with form, concrete has become a hallmark material to ennoble urban spaces, transmit the sense of monumentality and create elegant and long-lasting solutions in different architectural and landscape contexts.

Going a step further Bellitalia invented UTC® - a mix of UHPC that challenges traditional perception of concrete and its qualities. This groundbreaking material is 10 times more durable than traditional concrete, yet 5 times thinner. For these reasons UHPC has been widely used in contemporary architecture to transmit a sense of lightness and translucency, without sacrificing the quality.

Bellitalia® is a part of the **THE PLACEMAKERS** - the world's biggest urban manufacturer that is exclusively committed to anticipating future trends and designing urban spaces that would enhance interpersonal connections, citizens' wellbeing and human relationships.

A PATH TOWARDS ENERGY EFFICIENCY

The PLACE-MAKING is the cornerstone of our philosophy. We are responsible to make the urban spaces better, safer and more comfortable for people, but we are responsible for the environment that surrounds these spaces as well: the quality of air we breathe, the soil, the depletion of water. We believe that our ability to reduce our impact on the environment is just as important as how we make our products.

From the beginning we have been investing in renewable energy solutions. An extensive roof photovoltaic system consists of 7.384 solar panels of 1,7 mWp and, installed on the roofs of the group's manufacturing facilities, fulfills the all energy need. This prevents the emission of about 5.000 tons of CO2 into the atmosphere every year, an amount of CO2 produced on average by 300 homes.

The aggregates used are locally sourced from the surrounding dolomitic areas, thus reducing our CO2 impact. We also use of purified rainwater, minimizing our consumption of aqueduct water. And we only apply eco-friendly treatments that do not pollute soil, water and are healthy for people who use them.

THE PLACEMAKERS strive to become the world's first carbon-neutral urban manufacturing group. This takes continuous commitment to environmental sustainability and implementation of the new practices.

ENVIRONMENTAL CONSCIOUSNESS

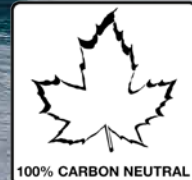

Conscious use of raw materials at THE PLACEMAKERS is based on two principles - efficiency and recycling. Efficiency is about not using more resources than you need and maximizing the ones you already have. Recycling is about creating products that can be harmoniously brought back into the system.

THE PLACEMAKERS group has established special processes and protocols for sourcing the precious stones or PMD. Marble chips created by breaking giant marble slabs are recycled directly from the quarries in Italy, including the region of Carrara.

Carrara's marble has been made famous by Michelangelo, who used it in his most renowned sculptures, David and The Pietà. WPC material is obtained from suppliers that use only recycled wood fibers and thermoplastics to create this innovative material.

Any residuum produced during our internal manufacturing process is further recycled and re-elaborated into the future products.

We've also have an in-house team that is responsible for our product design optimization, making sure that every inch of our raw materials is not wasted.

All these initiatives are directed towards the group's "ZERO WASTE" policy.

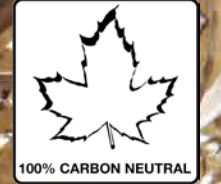

MINDFUL USE OF PRECIOUS RAW MATERIALS

100% RECYCLABLE

Many of the materials we've chosen for our projects, including prime Corten and Stainless steel are already one of the world's most-recycled materials.

As to our concrete, UHPC and precious stone compounds, the absence of resins and aggressive chemicals, makes them 100% recyclable as well.

What's more, all of the materials we use in our products maintain their quality and purity and can be recycled endlessly to give life to new urban products and projects.

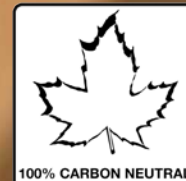

100% SUSTAINED WOOD

All of our wood comes from sustainably managed forests that do not contribute to deforestation and that treat their workers fairly. Even the sawdust and wood chips are recycled from the wood processing facilities with the raw materials carefully analyzed and selected.

PRODUCTS THAT ARE MEANT TO LAST

One of the biggest differentiators of any product's quality is its durability. We believe that better things should last longer... preferably a lifetime.

It involves asking some important questions and begins as early as the design phase. We make sure that single components can easily be replaced without the need to disassemble the entire product. We calculate the thickness of the wood to be significant, without being wasteful and choose the materials, such as Stainless steel and Corten steel, that are weather-resistant without the use of any additional treatments and do not require any maintenance. It is with these small changes that a long-lasting environmental impact is created.

**SUSTAINABILITY
IS NOT A CLAIM OR
A MARKETING CAMPAIGN.
IT'S A CHOICE.
IT'S WHAT YOU DO DAY IN
AND DAY OUT,
WHEN NO ONE ELSE IS LOOKING.**

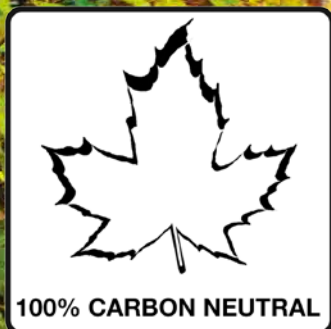

THE PLACEMAKERS
Making Spaces Living Places

INDEX PRODUCTS

32 PLANTERS

FIORIERE
JARDINERAS
JARDINIÈRES

34 CRISTINA ALPHA - BETA

44 MENHIR

48 MUG

54 PAWN

56 PRIMAVERA - ESTATE

62 STELO

66 TIMELESS

78 SPECIAL PROJECT

84 COMBINATIONS

COMBINAZIONI
COMBINACIONES
COMBINAISONS

84 820 PONTE

86 1220 PONTE

88 1220 CIRCOLARE

90 BENCHES

PANCHE
BANCOS
BANCS

92 AFRODITE

94 AURELIA D - C

98 CITTÀ

100 GEA

108 MENHIR

112 ROMANA D - C

116 OUTDOOR TABLE

TAVOLO DA ESTERNO
MESA AL AIRE LIBRE
TABLE EXTÉRIEURE

116 ICARO

120 BOLLARDS

DISSUASORI
BOLARDOS
BORNES

122 ARO

124 IKI

126 KID - TIP

128 MEL

130 RAY

132 TITANO

136 COSMOARREDO

142 LITTER BINS

CESTINI
PAPELERAS
CORBEILLERS

144 ATLANTE - CRONO - ERMES

148 CITTÀ

152 SORRENTO

158 RECYCLING POINT

ISOLA ECOLOGICA
ISLA ECOLÓGICA
ÎLE ÉCOLOGIQUE

160 RETROSCENA

168 QUINTA IRON

170 QUINTA WOOD

172 SHELTERS

PENSILINE
MARQUESINAS
ABRIS

174 MAGNUM EVOLUTION S - L

180 MAGNUM TRANSPARENT S - L

188 NEVE

192 FOUNTAINS

FONTANE
FUENTE
FONTAINES

196 ASOLA

198 CALLA

200 GIRASOLE

204 MARGHERITA

208 ORCHIDEA

212 QUADRIFOGLIO

216 SORAGA

LEGEND

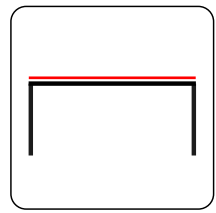

FINISHING ON THE SEATING SURFACE
FINITURA SUL PIANO DI SEDUTA
ACABADO DE LA SUPERFICIE DEL ASIENTO
FINITION SUR L'ASSISE

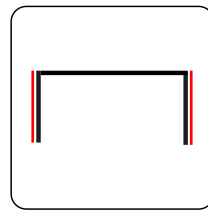

FINISHING ON SIDES
FINITURA LATERALE
ACABADO LATERAL
FINITION LATÉRALE

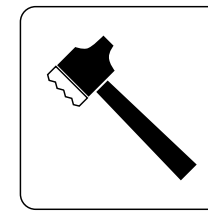

WITH BUSH-HAMMERING
CON BOCCIARDATURA
CON ABUJARDADO
AVEC BOUCHARDAGE

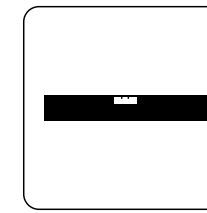

WITH LEVELLING SYSTEM
CON LIVELLAMENTO
CON NIVELACIÓN
AVEC NIVELLEMENT

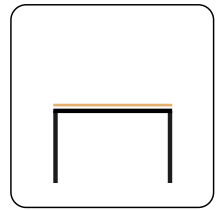

WOODEN SEAT
SEDUTA IN LEGNO
ASIENTO EN MADERA
ASSISE EN BOIS

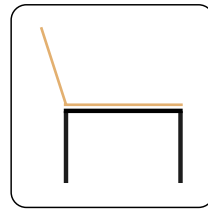

WOODEN SEAT AND BACKREST
SEDUTA E SCHIENALE IN LEGNO
ASIENTO Y RESPALDO EN MADERA
ASSISE ET DOSSIER EN BOIS

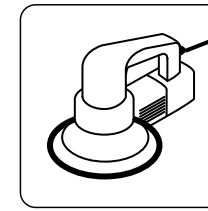

WITH POLISHING
CON LEVIGATURA
CON PULIDO
AVEC LISSAGE

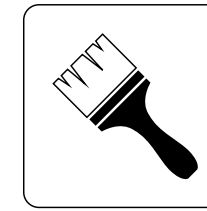

WITH ANTIDECAY
CON ANTIDEGRADO
CON ANTIDEGRADABLE
AVEC ANTI DÉGRADATION

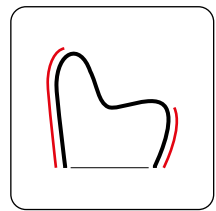

FINISHING ON SIDES
FINITURA LATERALE
ACABADO LATERAL
FINITION DES CÔTÉS

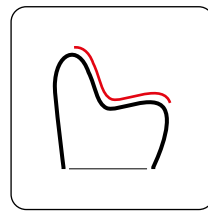

FINISHING ON THE SEATING SURFACE
FINITURA SUL PIANO DI SEDUTA
ACABADO DE LA SUPERFICIE DEL ASIENTO
FINITION DE L'ASSISE

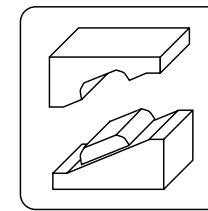

SMOOTH FORMWORK
LISCIO CASSERO
LISO
LISSE



WITH ANTI-GRAFFITI
CON ANTI-GRAFFITI
CON ANTI-GRAFFITI
AVEC ANTI-GRAFFITI

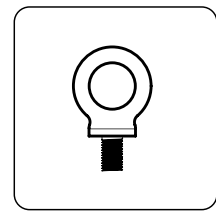

EYEBOLT
GOLFARE
CÁNCAMO
ANNEAU À TIGE

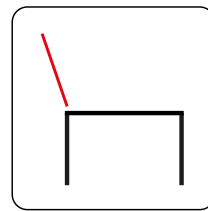

BACKREST
SCHIENALE
RESPALDO
DOSSIER

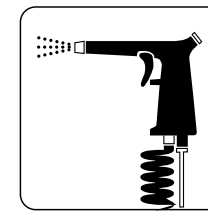

WITH SANDBLASTING
CON SABBIAURA
CON CHORRO DE ARENA
AVEC SABLAGE

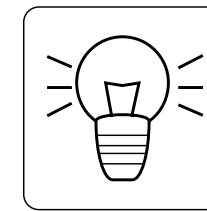

WITH LED LIGHT
CON LUCE LED
CON LUZ LED
AVEC LED

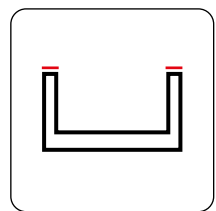

FINISHING ON UPPER RIM
FINITURA BORDO SUPERIORE
ACABADO DEL BORDE SUPERIOR
FINITION DU BORD SUPÉRIEUR

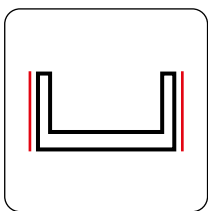

FINISHING ON SIDES
FINITURA LATERALE
ACABADO LATERAL
FINITION DES CÔTÉS

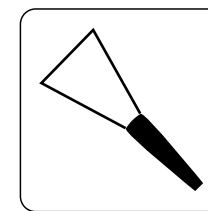

WITH ULTRASKIN
CON ULTRASKIN
CON ULTRASKIN
AVEC ULTRASKIN

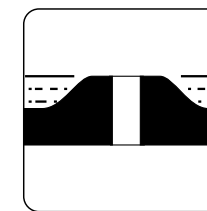

OVERFLOW DRAINAGE
SCARICO TROPPO PIENO
DRENAJE DE DESBORDAMIENTO
SYSTÈME DE TROP-PLEIN

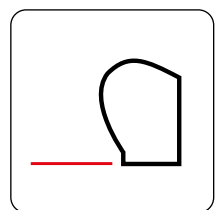

PERIMETRAL PLATES
PIASTRE PERIMETRALI
PLACAS PERIMETRALES
PLAQUES DU PÉRIMÈTRE

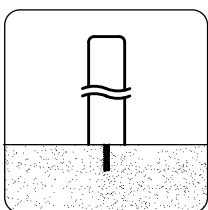

FIXING REQUIRED
NECESSARIO FISSAGGIO
FIJACIÓN NECESARIA
FIXATION NÉCESSAIRE



STAINLESS STEEL
ACCIAIO INOX
ACERO INOX
ACIER INOX

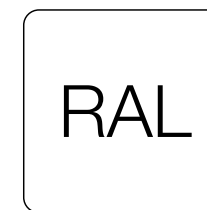

POWDER COATED STEEL
ACCIAIO VERNICIATO
ACERO PINTADO
ACIER THERMOLAQUÉ



PLANTERS
FIORIERE
JARDINERAS
JARDINIÈRES

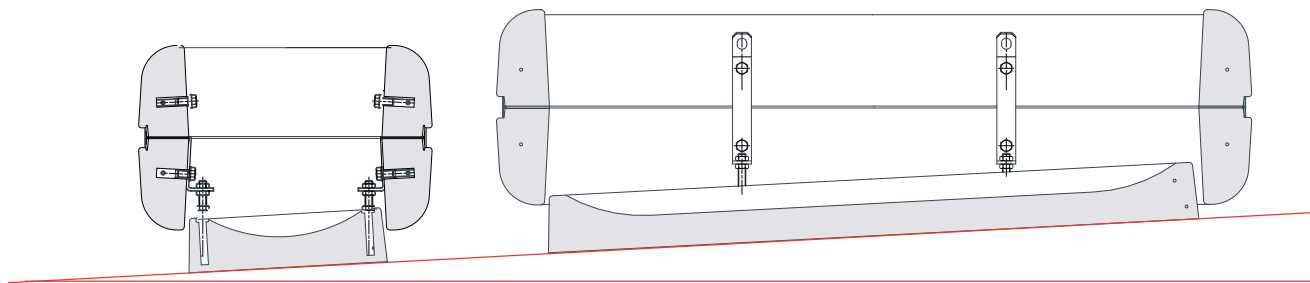

UNTIL **6%**

The leveling system is one of the main patented features that has made Bellitalia® products famous. This feature compensates for sloping ground with a gradient of up to 6%, achieving a levelled effect from a visual point of view.

Uno dei principali sistemi funzionali brevettati che hanno reso famosi i prodotti di Bellitalia®, è sicuramente il sistema di livellamento. Esso permette di compensare la pendenza del terreno fino ad un massimo del 6% ottenendo un effetto piano da un punto di vista visivo.

CRISTINA α - β WITH LEVELING SYSTEM

BELLITALIA DESIGN

Uno de los principales sistemas funcionales patentados que han hecho famosos a los productos Bellitalia® es, sin duda, el sistema de nivelación. Permite compensar la pendiente del suelo hasta un máximo del 6% obteniendo un efecto plano desde un punto de vista del conjunto.

Bellitalia® doit son succès aussi à un système breveté pour niveler le produit au sol: la pente du terrain jusqu'à 6% ainsi compensée horizontalement donne l'effet d'un élément posé droit.

CRISTINA α - β

BELLITALIA DESIGN







CRISTINA α - β

BELLITALIA DESIGN

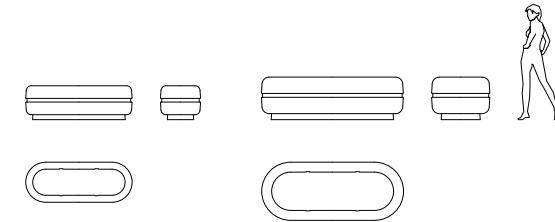
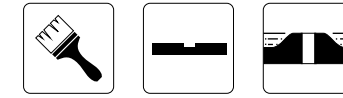

ALPHA
 L 1500 mm
 W 565 mm
 H 478 mm
 350 kg
 177 lt

BETA
 L 2000 mm
 W 820 mm
 H 600 mm
 880 kg
 410 lt



MATERIALS / MATERIALI / MATERIALES / MATÉRIAUX:

NATURAL MARBLE STONES	WHITE GRANITE	GREY CONCRETE
PIETRE DI MARMO NATURALI	GRANITO BIANCO	CEMENTO GRIGIO
PIEDRAS DE MÁRMOL NATURAL	GRANITO BLANCO	HORMIGÓN GRIS
PIERRES DE MARBRE NATURELLES	GRANIT BLANC	CIMENT GRIS



FINISHING / FINITURE / ACABADOS / FINITIONS:



ACCESSORIES / ACCESSORI / ACCESORIOS / ACCESSOIRES:



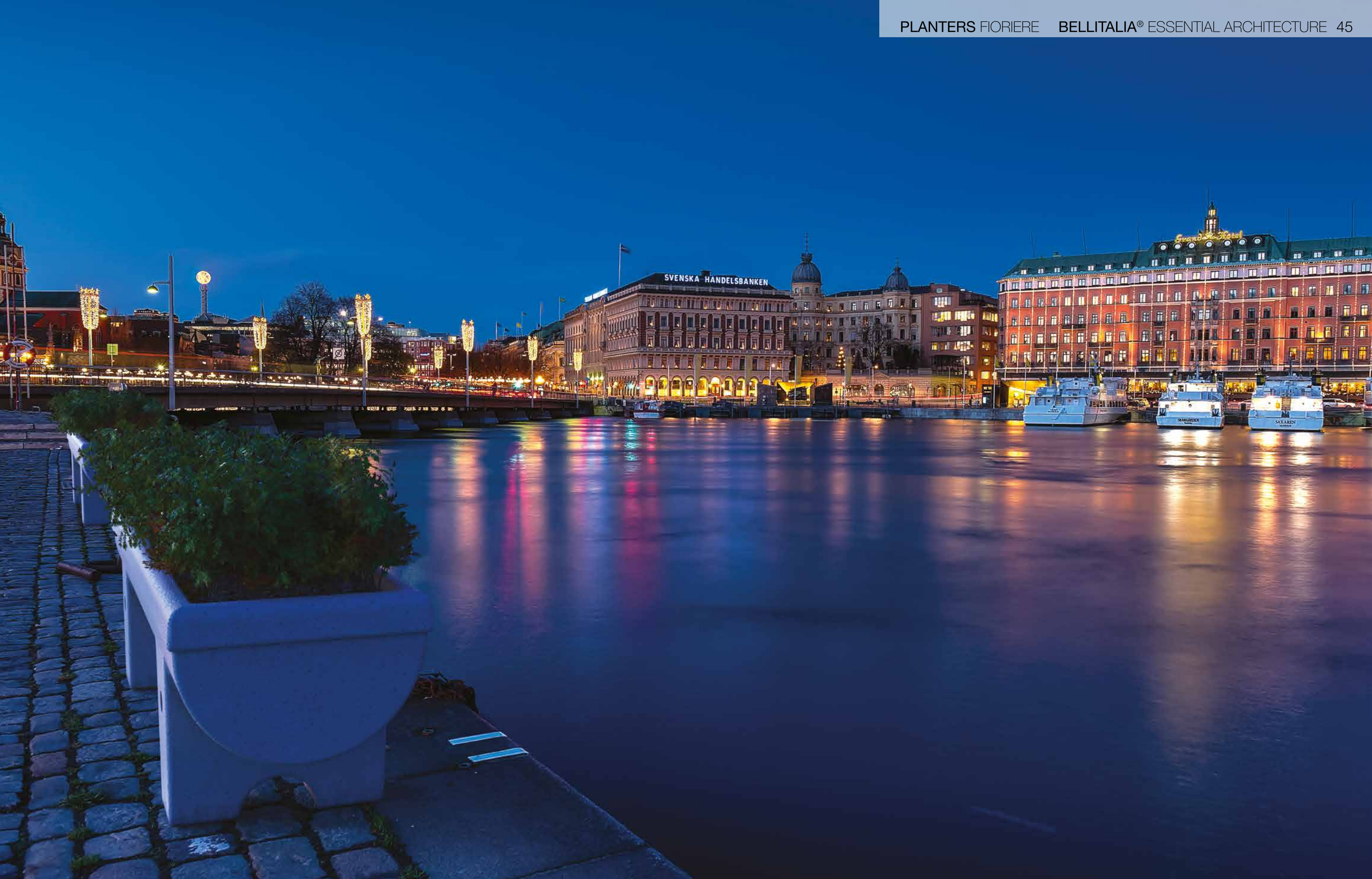

MENHIR

BELLITALIA DESIGN

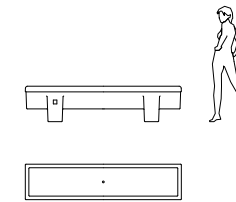
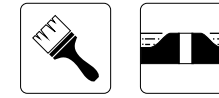

L 2200 mm
W 500 mm
H 500 mm
380 kg
115 lt



MATERIALS / MATERIALI / MATERIALES / MATÉRIAUX:

NATURAL MARBLE STONES	WHITE GRANITE	GREY CONCRETE
PIETRE DI MARMO NATURALI	GRANITO BIANCO	CEMENTO GRIGIO
PIEDRAS DE MÁRMOL NATURAL	GRANITO BLANCO	HORMIGÓN GRIS
PIERRES DE MARBRE NATURELLES	GRANIT BLANC	CIMENT GRIS



FINISHING / FINITURE / ACABADOS / FINITIONS:

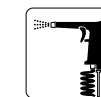

ACCESSORIES / ACCESSORI / ACCESORIOS / ACCESSOIRES:



MUG
BELLITALIA DESIGN



MUG

BELLITALIA DESIGN



UNTIL **10%**

MUG

BELLITALIA DESIGN

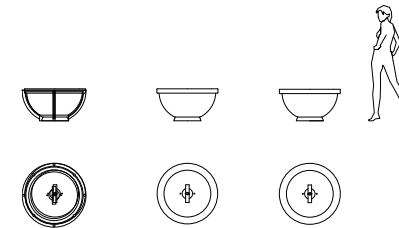
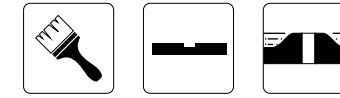

Ø 860 mm
H 451 mm
140 kg
80 lt

Ø 900 mm
H 435 mm
125 kg
80 lt



MATERIALS / MATERIALI / MATERIALES / MATÉRIAUX:

NATURAL MARBLE STONES	WHITE GRANITE	GREY CONCRETE
PIETRE DI MARMO NATURALI	GRANITO BIANCO	CEMENTO GRIGIO
PIEDRAS DE MÁRMOL NATURAL	GRANITO BLANCO	HORMIGÓN GRIS
PIERRES DE MARBRE NATURELLES	GRANIT BLANC	CIMENT GRIS



FINISHING / FINITURE / ACABADOS / FINITIONS:



ACCESSORIES / ACCESSORI / ACCESORIOS / ACCESSOIRES:

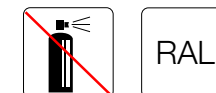

PAWN

BELLITALIA DESIGN

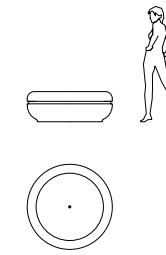
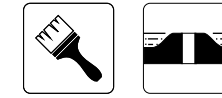

Ø 1200 mm
H 425 mm
620 kg
176 lt



MATERIALS / MATERIALI / MATERIALES / MATÉRIAUX:

NATURAL MARBLE STONES	WHITE GRANITE	GREY CONCRETE
PIETRE DI MARMO NATURALI	GRANITO BIANCO	CEMENTO GRIGIO
PIEDRAS DE MÁRMOL NATURAL	GRANITO BLANCO	HORMIGÓN GRIS
PIERRES DE MARBRE NATURELLES	GRANIT BLANC	CIMENT GRIS



FINISHES / FINITURE / ACABADOS / FINITIONS:

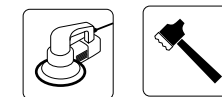

ACCESSORIES / ACCESSORI / ACCESORIOS / ACCESSOIRES:



PRIMAVERA - ESTATE

BELLITALIA DESIGN



PRIMAVERA - ESTATE

BELLITALIA DESIGN





PRIMAVERA - ESTATE

BELLITALIA DESIGN

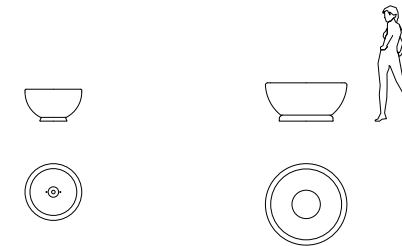
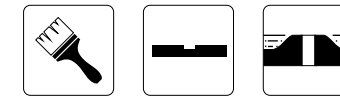

PRIMAVERA

Ø 800 mm
H 450 mm
135 kg
58 lt

ESTATE

L 1150 mm
H 540 mm
594 kg
191 lt

MATERIALS / MATERIALI / MATERIALES / MATÉRIAUX:

NATURAL MARBLE STONES	WHITE GRANITE
PIETRE DI MARMO NATURALI	GRANITO BIANCO
PIEDRAS DE MÁRMOL NATURAL	GRANITO BLANCO
PIERRES DE MARBRE NATURELLES	GRANIT BLANC

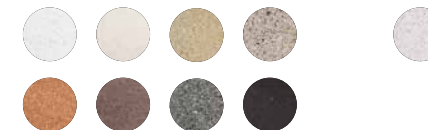

FINISHING / FINITURE / ACABADOS / FINITIONS:

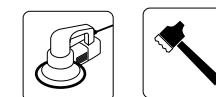

ACCESSORIES / ACCESSORI / ACCESORIOS / ACCESSOIRES:



STELO

BELLITALIA DESIGN





STELO

BELLITALIA DESIGN

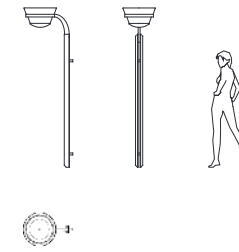

L 500 mm
W 700 mm
H 2496 mm
48 kg
32 lt

MATERIALS / MATERIALI / MATERIALES / MATÉRIAUX:

GALVANIZED STEEL
ACCIAIO ZINCATO
ACERO GALVANIZADO
ACIER GALVANISÉ



FINISHING / FINITURE / ACABADOS / FINITIONS:

RAL

TIMELESS

BELLITALIA DESIGN











TIMELESS

BELLITALIA DESIGN

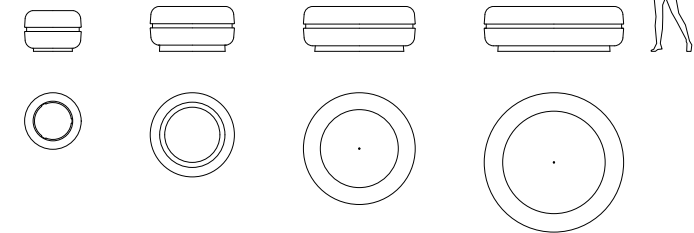
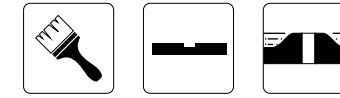

820	1220	1620	2020
Ø 820 mm	Ø 1220 mm	Ø 1620 mm	Ø 2020 mm
H 590 mm	H 650 mm	H 650 mm	H 650 mm
408 kg	910 kg	1468 kg	2114 kg
115 lt	300 lt	600 lt	1019 lt



MATERIALS / MATERIALI / MATERIALES / MATÉRIAUX:

NATURAL MARBLE STONES	WHITE GRANITE	GREY CONCRETE
PIETRE DI MARMO NATURALI	GRANITO BIANCO	CEMENTO GRIGIO
PIEDRAS DE MÁRMOL NATURAL	GRANITO BLANCO	HORMIGÓN GRIS
PIERRES DE MARBRE NATURELLES	GRANIT BLANC	CIMENT GRIS



FINISHING / FINITURE / ACABADOS / FINITIONS:



ACCESSORIES / ACCESSORI / ACCESORIOS / ACCESSOIRES:



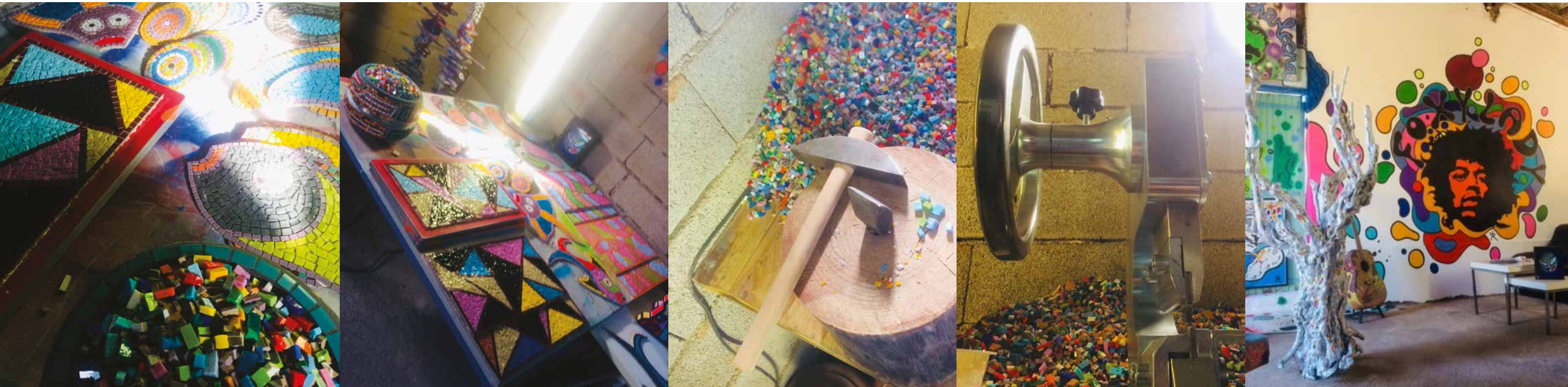

YANNICK ROBERT, aka YR, was born in 1973 in Sète, in the south of France, where he soon set about capturing the light and colours! His undying love for the patterns of light would play a pivotal role in his future choices.

He begins his career by teaching himself mosaic technique — which is complex but provides an outlet for the imagination with its colourful and alternating pieces of tile. His experience builds slowly, starting with the observation of artists such as Gaudi, Niki de Saint Phalle, Dubuffet, Cocteau and Miro, and then continues through travel. In 1997 he set off on a journey to discover Chile, the birthplace of his partner, where he visits to the modest workshops where local artists work to the lull of music; this awakens in him the need to make his mosaics and his art his true profession, as well as his calling in life.

With 2005 comes an important point in his career: his first showroom. Four years later YR starts a great project; he begins to embellish the streets of Palavas le Flots with an intricate and lively decoration of the planters and niches along the sea-front. YR himself suggested to the Municipality and to the Mayor that he undertake this project and only later, in 2013 with a trip to Rome, he learns that the planters in question are produced by Bellitalia.

YR works with sandstone tiles made with Venetian enamel. The creation of the mosaic and the assembling of the various pieces follow a completely personal technique, which at the same time refers to an ancient method adopted by the mosaic masters of ancient Rome.

So a set of identities, artistic figures and techniques converge in his way of making art. You could say YR is a free spirit: he applies his unique style, with its fusion of primitive and contemporary art, to everyday objects — a guitar, a notice-board, planters — turning them into living characters, multi-forms; through colour they are infused with a soul; they become unique.

Through his mosaics YR offers us an authentic, passionate and original look at his time and his way of conceiving art.

YANNICK ROBERT, in arte YR nasce nel 1973 a Sète, nel sud della Francia, di cui ha subito catturato luci e colori! Un amore quello dedicato ai giochi di luce, che ne caratterizzerà le scelte future.

Vede l'inizio della sua carriera con lo studio da autodidatta della tecnica del mosaico, complessa ma in grado di dare sfogo alla fantasia e di prendere vita attraverso tessere colorate e cangianti. La sua esperienza si costruisce pian piano, partendo dall'osservazione di artisti come Gaudi, Niki de Saint Phalle, Dubuffet, Cocteau e Miro, per poi continuare attraverso i viaggi. Nel 1997 parte per un viaggio alla scoperta del Cile, paese natale della sua compagna, dove le visite ai modesti laboratori in cui gli artisti locali lavorano cullati dalla musica, risvegliano in lui la necessità di fare dei suoi mosaici e della sua arte una vera e propria professione, nonché necessità di vita.

Col 2005 arriva un punto importante della sua carriera: il suo primo showroom. Quattro anni dopo nasce un grande progetto, inizia infatti ad abbellire le strade di Palavas le Flots, attraverso una decorazione complessa e vivace delle fioriere e nicchie poste lungo il mare; lui stesso ha proposto al Comune e al Sindaco di intraprendere questo progetto e solo successivamente, nel 2013 con un viaggio a Roma, viene a conoscenza che le fioriere in questione sono di produzione di Bellitalia.

YR lavora con piastrelle di arenaria realizzate con smalto veneziano. La creazione del mosaico e l'assemblaggio dei vari tasselli segue una tecnica completamente personale, ma che allo stesso tempo si rifà ad una tecnica antica adottata dai maestri mosaicisti dell'antica Roma.

Quindi un insieme di identità, di figure artistiche e di tecniche confluiscono nel suo modo di fare arte. Stiamo parlando di uno spirito libero, in grado di trasformare l'arte primitiva e la manifestazione contemporanea in una forma d'espressione tutta personale e unica, che vede applicazione fisica su oggetti di uso quotidiano, come una chitarra, una lavagna oppure delle fioriere, trasformandoli in personaggi viventi, multiformi che attraverso il colore si caricano di un'anima tutta loro e unica.

Attraverso i suoi mosaici YR ci offre uno sguardo autentico, passionale e originale sul suo tempo e il suo modo di concepire l'arte.

SPECIAL PROJECTS







Ø 820 + PONTE

BELLITALIA DESIGN

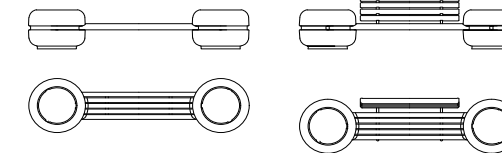
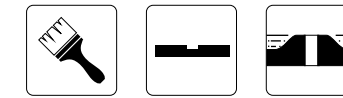

Ø 820 mm
L 3182 mm
H 590 mm
858 kg

Ø 820 mm
L 3182 mm
H 797 mm
876 kg

MATERIALS / MATERIALI / MATERIALES / MATÉRIAUX:

NATURAL MARBLE STONES
PIETRE DI MARMO NATURALI
PIEDRAS DE MÁRMOL NATURAL
PIERRES DE MARBRE NATURELLES

WHITE GRANITE
GRANITO BIANCO
GRANITO BLANCO
GRANIT BLANC

GREY CONCRETE
CEMENTO GRIGIO
HORMIGÓN GRIS
CIMENT GRIS

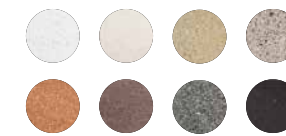

WOOD
LEGNO
MADERA
BOIS



FINISHING / FINITURE / ACABADOS / FINITIONS:



ACCESSORIES / ACCESSORI / ACCESORIOS / ACCESSOIRES:



Ø 1220 + PONTE

BELLITALIA DESIGN

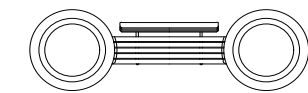
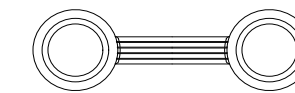
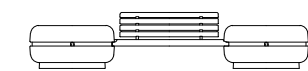
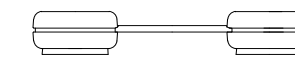
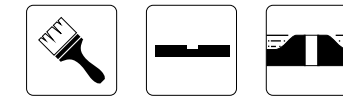

Ø 1220 mm
L 4018 mm
H 650 mm
1862 kg

Ø 1220 mm
L 4018 mm
H 850 mm
1880 kg

MATERIALS / MATERIALI / MATERIALES / MATÉRIAUX:

NATURAL MARBLE STONES
PIETRE DI MARMO NATURALI
PIEDRAS DE MÁRMOL NATURAL
PIERRES DE MARBRE NATURELLES

WHITE GRANITE
GRANITO BIANCO
GRANITO BLANCO
GRANIT BLANC

GREY CONCRETE
CEMENTO GRIGIO
HORMIGÓN GRIS
CIMENT GRIS



WOOD
LEGNO
MADERA
BOIS



FINISHING / FINITURE / ACABADOS / FINITIONS:



ACCESSORIES / ACCESSORI / ACCESORIOS / ACCESSOIRES:





Ø 1220 + CIRCOLARE

BELLITALIA DESIGN

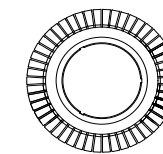
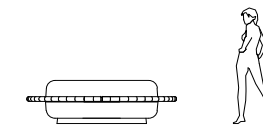
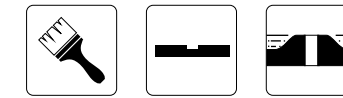

Ø 1760 mm
H 650 mm
990 kg
300 lt

MATERIALS / MATERIALI / MATERIALES / MATÉRIAUX:

NATURAL MARBLE STONES
PIETRE DI MARMO NATURALI
PIEDRAS DE MÁRMOL NATURAL
PIERRES DE MARBRE NATURELLES

WHITE GRANITE
GRANITO BIANCO
GRANITO BLANCO
GRANIT BLANC

GREY CONCRETE
CEMENTO GRIGIO
HORMIGÓN GRIS
CIMENT GRIS

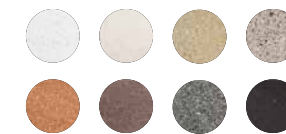

WOOD
LEGNO
MADERA
BOIS



FINISHING / FINITURE / ACABADOS / FINITIONS:



ACCESSORIES / ACCESSORI / ACCESORIOS / ACCESSOIRES:

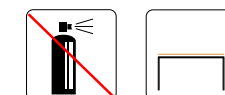

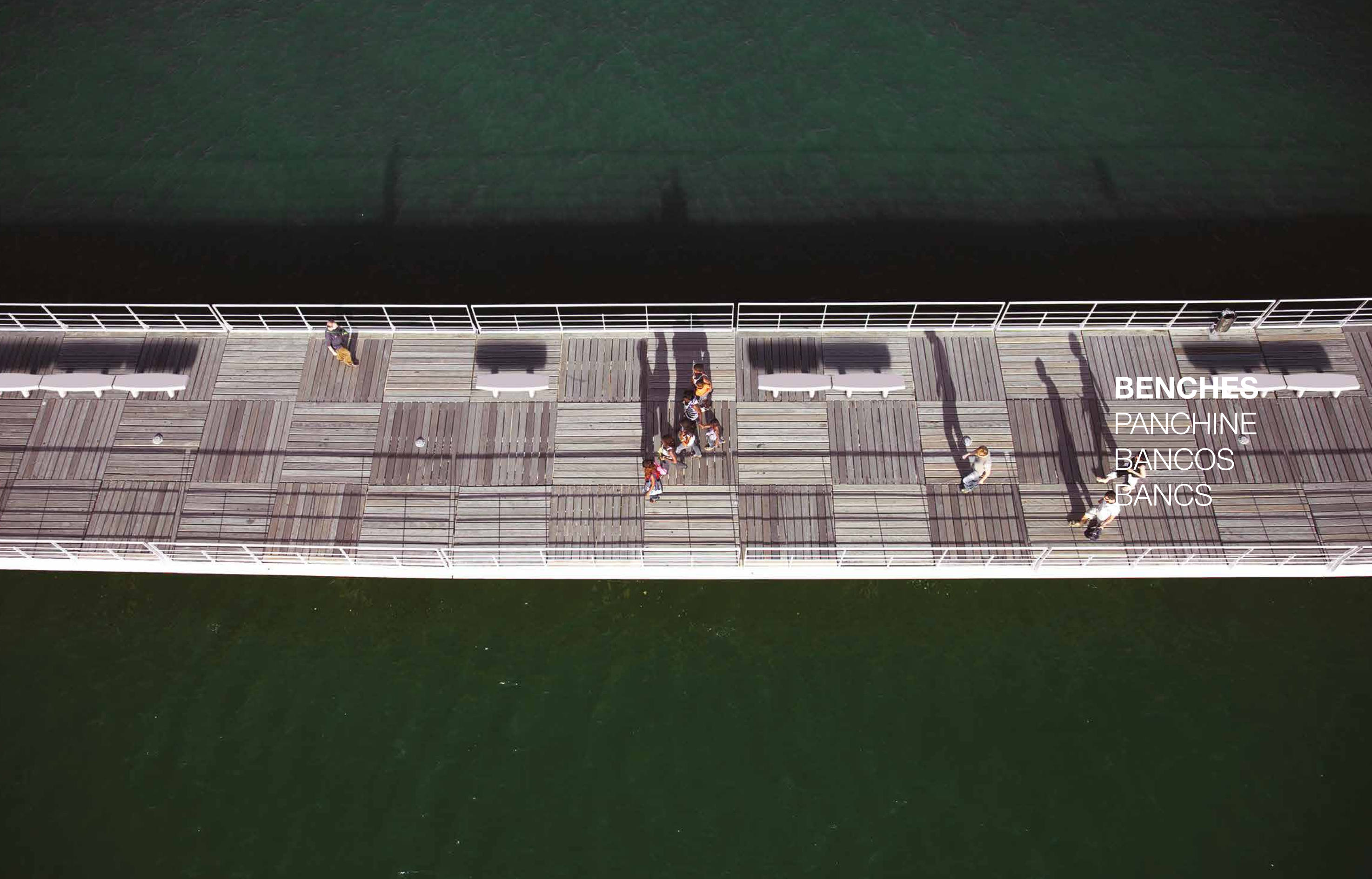

BENCHES
PANCHINE
BANCOS
BANCS



AFRODITE

BELLITALIA DESIGN

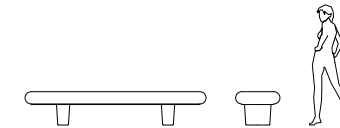

L 2450 mm
W 600 mm
H 451 mm
610 kg

MATERIALS / MATERIALI / MATERIALES / MATÉRIAUX:
 NATURAL MARBLE STONES
 PIETRE DI MARMO NATURALI
 PIEDRAS DE MÁRMOL NATURAL
 PIERRES DE MARBRE NATURELLES
 WHITE GRANITE
 GRANITO BIANCO
 GRANITO BLANCO
 GRANIT BLANC



FINISHING / FINITURE / ACABADOS / FINITIONS:

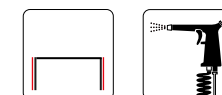

ACCESSORIES / ACCESSORI / ACCESORIOS / ACCESSOIRES:



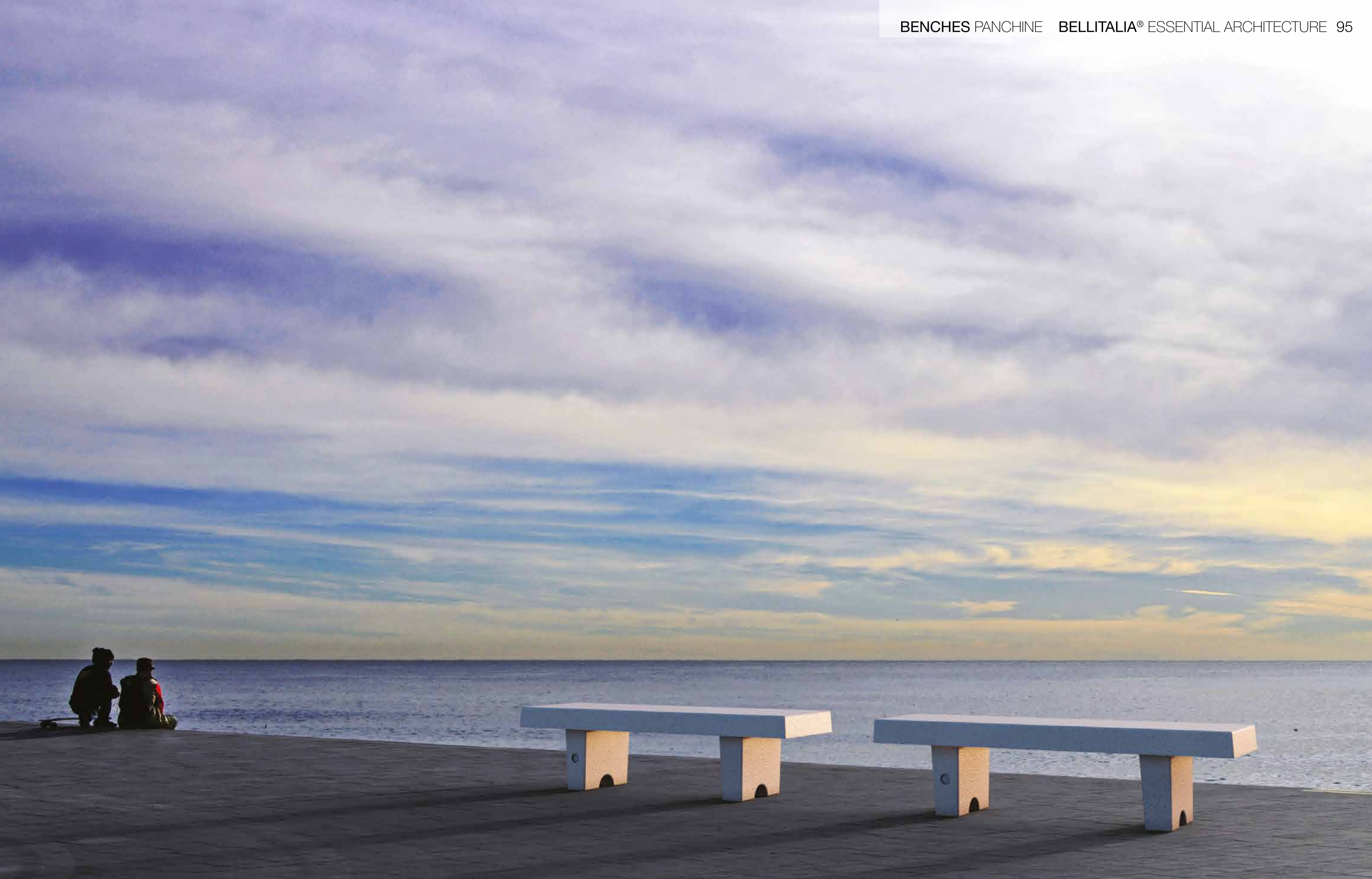

AURELIA D - C

BELLITALIA DESIGN

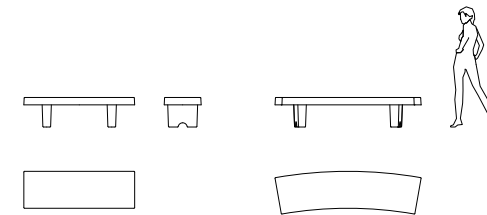

AURELIA D
L 1500 mm
W 500 mm
H 400 mm
243 kg

AURELIA C
L 1979 mm
W 578 mm
H 400 mm
290 kg

MATERIALS / MATERIALI / MATERIALES / MATÉRIAUX:
NATURAL MARBLE STONES
PIETRE DI MARMO NATURALI
PIEDRAS DE MÁRMOL NATURAL
PIERRES DE MARBRE NATURELLES
WHITE GRANITE
GRANITO BIANCO
GRANITO BLANCO
GRANIT BLANC



FINISHING / FINITURE / ACABADOS / FINITIONS:

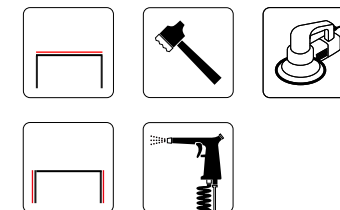

ACCESSORIES / ACCESSORI / ACCESORIOS / ACCESSOIRES:



CITTÀ

BELLITALIA DESIGN

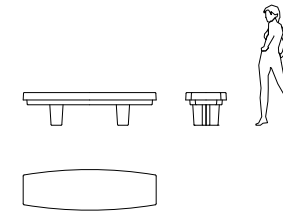

L 1800 mm
W 550 mm
H 442 mm
368 kg



MATERIALS / MATERIALI / MATERIALES / MATÉRIAUX:

NATURAL MARBLE STONES	WHITE GRANITE	GREY CONCRETE
PIETRE DI MARMO NATURALI	GRANITO BIANCO	CEMENTO GRIGIO
PIEDRAS DE MÁRMOL NATURAL	GRANITO BLANCO	HORMIGÓN GRIS
PIERRES DE MARBRE NATURELLES	GRANIT BLANC	CIMENT GRIS



FINISHING / FINITURE / ACABADOS / FINITIONS:



ACCESSORIES / ACCESSORI / ACCESORIOS / ACCESSOIRES:











GEA

BELLITALIA DESIGN

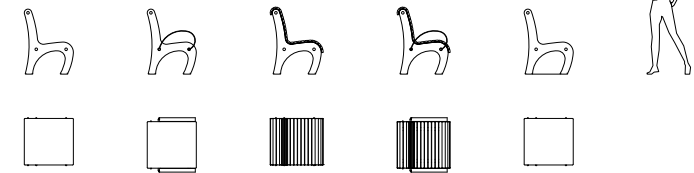

L 630 mm
W 664 mm
H 880 mm
290 kg

L 630 mm
W 664 mm
H 900 mm
302 kg

L 630 mm
W 664 mm
H 880 mm
330 kg

MATERIALS / MATERIALI / MATERIALES / MATÉRIAUX:

NATURAL MARBLE STONES
PIETRE DI MARMO NATURALI
PIEDRAS DE MÁRMOL NATURAL
PIERRES DE MARBRE NATURELLES

WHITE GRANITE
GRANITO BIANCO
GRANITO BLANCO
GRANIT BLANC

WOOD
LEGNO
MADERA
BOIS



FINISHING / FINITURE / ACABADOS / FINITIONS:



ACCESSORIES / ACCESSORI / ACCESORIOS / ACCESSOIRES:







MENHIR

BELLITALIA DESIGN

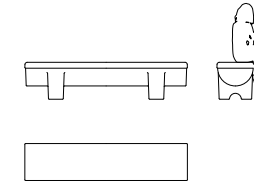

L 2200 mm
W 500 mm
H 500 mm
780 kg

MATERIALS / MATERIALI / MATERIALES / MATÉRIAUX:

NATURAL MARBLE STONES
PIETRE DI MARMO NATURALI
PIEDRAS DE MÁRMOL NATURAL
PIERRES DE MARBRE NATURELLES

WHITE GRANITE
GRANITO BIANCO
GRANITO BLANCO
GRANIT BLANC

GREY CONCRETE
CEMENTO GRIGIO
HORMIGÓN GRIS
CIMENT GRIS



FINISHING / FINITURE / ACABADOS / FINITIONS:

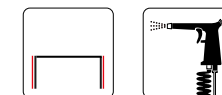

ACCESSORIES / ACCESSORI / ACCESORIOS / ACCESSOIRES:



ROMANA D - C

BELLITALIA DESIGN



ROMANA D - C

BELLITALIA DESIGN

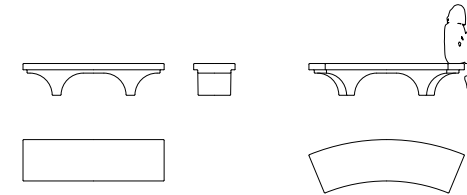

ROMANA D
L 1910 mm
W 560 mm
H 430 mm
490 kg

ROMANA C
L 2109 mm
W 725 mm
H 430 mm
530 kg

MATERIALS / MATERIALI / MATERIALES / MATÉRIAUX:
NATURAL MARBLE STONES
PIETRE DI MARMO NATURALI
PIEDRAS DE MÁRMOL NATURAL
PIERRES DE MARBRE NATURELLES
WHITE GRANITE
GRANITO BIANCO
GRANITO BLANCO
GRANIT BLANC



FINISHING / FINITURE / ACABADOS / FINITIONS:

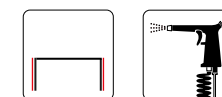

ACCESSORIES / ACCESSORI / ACCESORIOS / ACCESSOIRES:





ICARO

BELLITALIA DESIGN

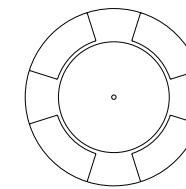
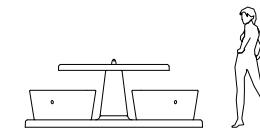

Ø 2400 mm
H 850 mm
2366 kg



MATERIALS / MATERIALI / MATERIALES / MATÉRIAUX:
 NATURAL MARBLE STONES
 PIETRE DI MARMO NATURALI
 PIEDRAS DE MÁRMOL NATURAL
 PIERRES DE MARBRE NATURELLES
 WHITE GRANITE
 GRANITO BIANCO
 GRANITO BLANCO
 GRANIT BLANC



FINISHING / FINITURE / ACABADOS / FINITIONS:

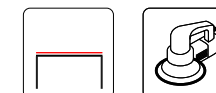

ACCESSORIES / ACCESSORI / ACCESORIOS / ACCESSOIRES:





KID



TIP



TITANO



IKI



COSMOARREDO



ARO



RAY



MEL

BOLLARDS
DISSUASORI
BOLARDOS
BORNE

ARO

BELLITALIA DESIGN



Ø 404 mm
H 783 mm
182 kg



MATERIALS / MATERIALI / MATERIALES / MATÉRIAUX:

NATURAL MARBLE STONES
PIETRE DI MARMO NATURALI
PIEDRAS DE MÁRMOL NATURAL
PIERRES DE MARBRE NATURELLES

WHITE GRANITE
GRANITO BIANCO
GRANITO BLANCO
GRANIT BLANC

GREY CONCRETE
CEMENTO GRIGIO
HORMIGÓN GRIS
CIMENT GRIS



FINISHING / FINITURE / ACABADOS / FINITIONS:



ACCESSORIES / ACCESSORI / ACCESORIOS / ACCESSOIRES:





IKI

BELLITALIA DESIGN

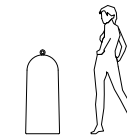

Ø 430 mm
H 1064 mm
300 kg

MATERIALS / MATERIALI / MATERIALES / MATÉRIAUX:

NATURAL MARBLE STONES
PIETRE DI MARMO NATURALI
PIEDRAS DE MÁRMOL NATURAL
PIERRES DE MARBRE NATURELLES

WHITE GRANITE
GRANITO BIANCO
GRANITO BLANCO
GRANIT BLANC

GREY CONCRETE
CEMENTO GRIGIO
HORMIGÓN GRIS
CIMENT GRIS



FINISHING / FINITURE / ACABADOS / FINITIONS:



ACCESSORIES / ACCESSORI / ACCESORIOS / ACCESSOIRES:



KID - TIP

BELLITALIA DESIGN



KID
Ø 322 mm
H 319 mm
46 kg

TIP
Ø 406 mm
H 514 mm
116 kg

**MATERIALS / MATERIALI / MATERIALES / MATÉRIAUX:**

NATURAL MARBLE STONES
PIETRE DI MARMO NATURALI
PIEDRAS DE MÁRMOL NATURAL
PIERRES DE MARBRE NATURELLES

WHITE GRANITE
GRANITO BIANCO
GRANITO BLANCO
GRANIT BLANC

GREY CONCRETE
CEMENTO GRIGIO
HORMIGÓN GRIS
CIMENT GRIS

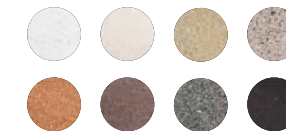
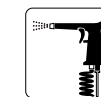
**FINISHING / FINITURE / ACABADOS / FINITIONS:****ACCESSORIES / ACCESSORI / ACCESORIOS / ACCESSOIRES:**

MEL

BELLITALIA DESIGN



Ø 445 mm
H 784 mm
210 kg



MATERIALS / MATERIALI / MATERIALES / MATÉRIAUX:

NATURAL MARBLE STONES
PIETRE DI MARMO NATURALI
PIEDRAS DE MÁRMOL NATURAL
PIERRES DE MARBRE NATURELLES

WHITE GRANITE
GRANITO BIANCO
GRANITO BLANCO
GRANIT BLANC

GREY CONCRETE
CEMENTO GRIGIO
HORMIGÓN GRIS
CIMENT GRIS

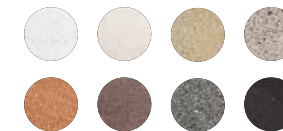

FINISHING / FINITURE / ACABADOS / FINITIONS:



ACCESSORIES / ACCESSORI / ACCESORIOS / ACCESSOIRES:



RAY

BELLITALIA DESIGN

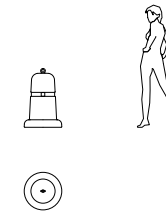

Ø 500 mm
H 784 mm
200 kg



MATERIALS / MATERIALI / MATERIALES / MATÉRIAUX:

NATURAL MARBLE STONES
PIETRE DI MARMO NATURALI
PIEDRAS DE MÁRMOL NATURAL
PIERRES DE MARBRE NATURELLES

WHITE GRANITE
GRANITO BIANCO
GRANITO BLANCO
GRANIT BLANC

GREY CONCRETE
CEMENTO GRIGIO
HORMIGÓN GRIS
CIMENT GRIS



FINISHING / FINITURE / ACABADOS / FINITIONS:



ACCESSORIES / ACCESSORI / ACCESORIOS / ACCESSOIRES:



TITANO

BELLITALIA DESIGN





TITANO

BELLITALIA DESIGN



Ø 500 mm
H 579 mm
200 kg

MATERIALS / MATERIALI / MATERIALES / MATÉRIAUX:

NATURAL MARBLE STONES
PIETRE DI MARMO NATURALI
PIEDRAS DE MÁRMOL NATURAL
PIERRES DE MARBRE NATURELLES

WHITE GRANITE
GRANITO BIANCO
GRANITO BLANCO
GRANIT BLANC

GREY CONCRETE
CEMENTO GRIGIO
HORMIGÓN GRIS
CIMENT GRIS

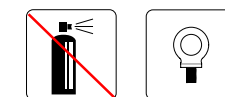
**FINISHING / FINITURE / ACABADOS / FINITIONS:****ACCESSORIES / ACCESSORI / ACCESORIOS / ACCESSOIRES:**

COSMOARREDO

BELLITALIA DESIGN



COSMOARREDO

BELLITALIA DESIGN

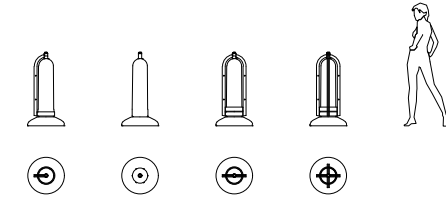

COSMO

Ø 520 mm
H 1054 mm
120 / 127 / 138 kg

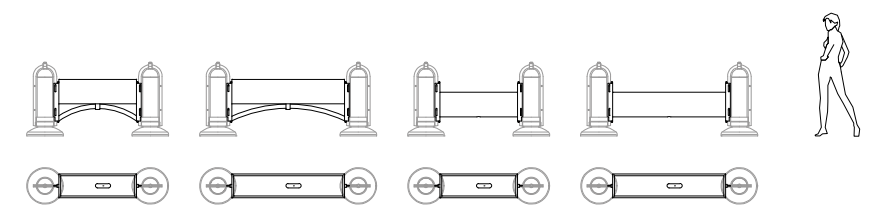

COSMO H

L 1500 mm
W 510 mm
H 810 mm
298 kg

L 2000 mm
W 510 mm
H 810 mm
313 kg

COSMO L

L 1500 mm
W 510 mm
H 620 mm
298 kg

L 2000 mm
W 510 mm
H 620 mm
313 kg



COSMOARREDO

BELLITALIA DESIGN



MATERIALS / MATERIALI / MATERIALES / MATÉRIAUX:

NATURAL MARBLE STONES
PIETRE DI MARMO NATURALI
PIEDRAS DE MÁRMOL NATURAL
PIERRES DE MARBRE NATURELLES

WHITE GRANITE
GRANITO BIANCO
GRANITO BLANCO
GRANIT BLANC

GALVANIZED STEEL
ACCIAIO ZINCATO
ACERO GALVANIZADO
ACIER GALVANISÉ

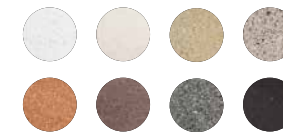

FINISHING / FINITURE / ACABADOS / FINITIONS:



ACCESSORIES / ACCESSORI / ACCESORIOS / ACCESSOIRES:





LITTER BINS
CESTINI
PAPELERAS
CORBEILLES

ATLANTE - CRONO - ERMES

BELLITALIA DESIGN



ATLANTE - CRONO - ERMES

BELLITALIA DESIGN

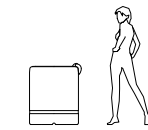

ATLANTE
 Ø 674 mm
 H 1117 mm
 380 kg
 120 lt

CRONO
 Ø 674 mm
 H 970 mm
 355 kg
 23 lt

ERMES
 Ø 674 mm
 H 842 mm
 360 kg
 120 lt

MATERIALS / MATERIALI / MATERIALES / MATÉRIAUX:

NATURAL MARBLE STONES	WHITE GRANITE
PIETRE DI MARMO NATURALI	GRANITO BIANCO
PIEDRAS DE MÁRMOL NATURAL	GRANITO BLANCO
PIERRES DE MARBRE NATURELLES	GRANIT BLANC

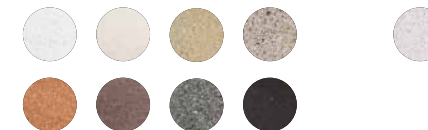

FINISHING / FINITURE / ACABADOS / FINITIONS:



ACCESSORIES / ACCESSORI / ACCESORIOS / ACCESSOIRES:



RAL

INOX



CITTÀ
BELLITALIA DESIGN



CITTÀ

BELLITALIA DESIGN

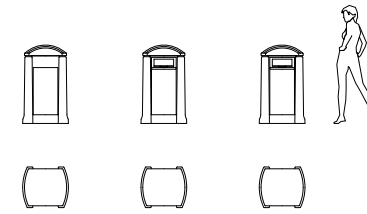

L 630 mm
W 560 mm
H 1080 mm
335 kg
106 lt

MATERIALS / MATERIALI / MATERIALES / MATÉRIAUX:

NATURAL MARBLE STONES	WHITE GRANITE	GALVANIZED STEEL
PIETRE DI MARMO NATURALI	GRANITO BIANCO	ACCIAIO ZINCATO
PIEDRAS DE MÁRMOL NATURAL	GRANITO BLANCO	ACERO GALVANIZADO
PIERRES DE MARBRE NATURELLES	GRANIT BLANC	ACIER GALVANISÉ



FINISHING / FINITURE / ACABADOS / FINITIONS:

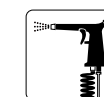

ACCESSORIES / ACCESSORI / ACCESORIOS / ACCESSOIRES:



SORRENTO

BELLITALIA DESIGN



SORRENTO

BELLITALIA DESIGN





SORRENTO

BELLITALIA DESIGN

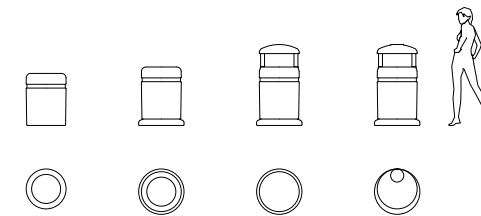

Ø 550 mm
H 717 mm
210 kg
80 lt

Ø 550 mm
H 1115 mm
287 kg
80 lt

MATERIALS / MATERIALI / MATERIALES / MATÉRIAUX:

NATURAL MARBLE STONES	WHITE GRANITE
PIETRE DI MARMO NATURALI	GRANITO BIANCO
PIEDRAS DE MÁRMOL NATURAL	GRANITO BLANCO
PIERRES DE MARBRE NATURELLES	GRANIT BLANC



FINISHING / FINITURE / ACABADOS / FINITIONS:



ACCESSORIES / ACCESSORI / ACCESORIOS / ACCESSOIRES:





RECYCLING POINTS

ISOLA ECOLOGICA

ISLA ECOLÓGICA

ÎLE ÉCOLOGIQUE



On request, the ecological island can be equipped with an electronic lock with combination. Useful for all those situations where personalized and reserved access to more people is required.

L'isola ecologica può essere dotata, a richiesta, di apertura con serratura elettronica con combinazione. Utile per tutte quelle situazioni in cui è richiesto l'accesso personalizzato e riservato a più persone.

RETROSCENA

BELLITALIA DESIGN

Bajo pedido, la isla ecológica puede equiparse con una cerradura electrónica con combinación. Útil para todas aquellas situaciones donde se requiere acceso personalizado y reservado a más personas.

L'île poubelle peut être équipée sur demande de fermeture électronique avec code, très utile quand l'accès est réservé à différentes personnes.

RETROSCENA

BELLITALIA DESIGN



RECYCLING POINT **OPEN**

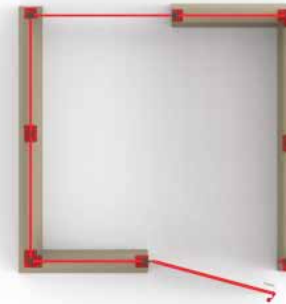

RECYCLING POINT **MINI**

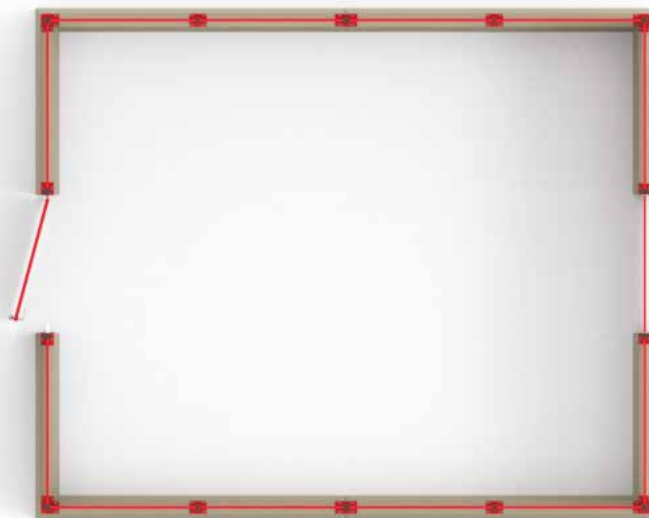

RECYCLING POINT **MAXI**

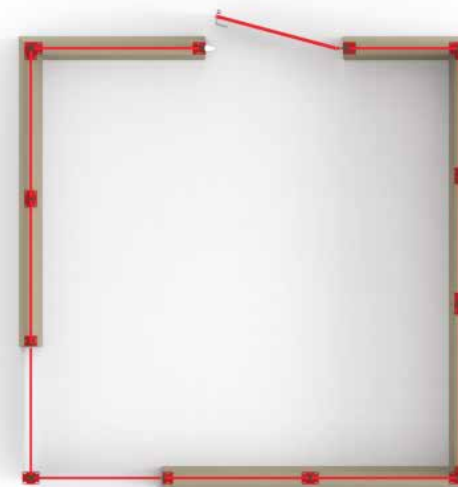

RECYCLING POINT **MEDIUM**

RETROSCENA

BELLITALIA DESIGN

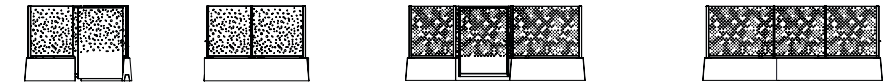

MINI

L 2955 mm
W 2824 mm
H 1972 mm
2624 kg

MEDIUM

L 4750 mm
W 4750 mm
H 1972 mm
4552 kg

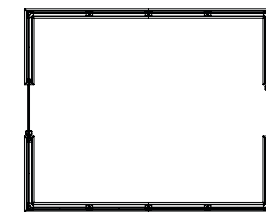

MAXI

L 6502 mm
W 5348 mm
H 1972 mm
6390 kg

RETROSCENA

BELLITALIA DESIGN

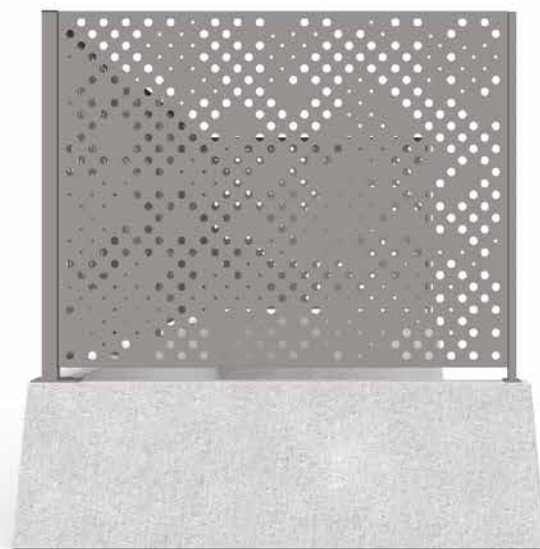
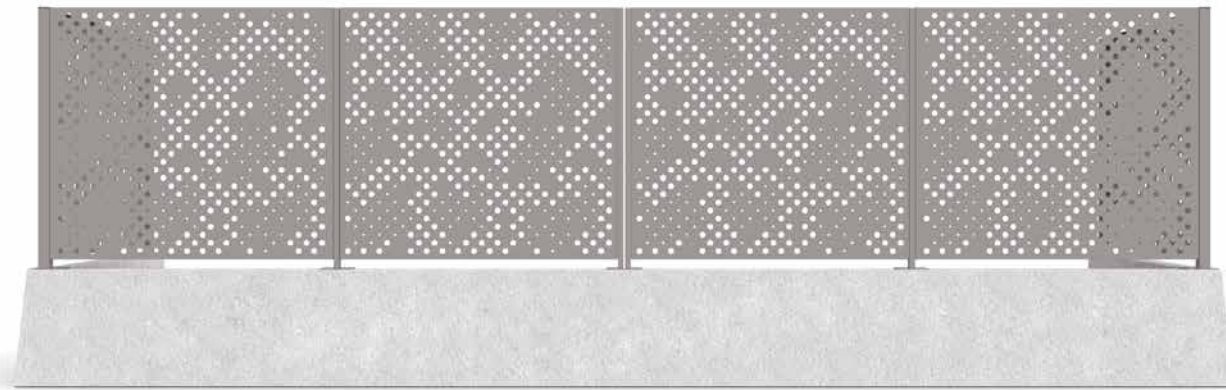

OPEN

L 6502 mm

W 2000 mm

H 1972 mm

3233 kg

MATERIALS / MATERIALI / MATERIALES / MATÉRIAUX:

WHITE GRANITE	POWDER COATED STEEL
GRANITO BIANCO	ACCIAIO VERNICIATO
GRANITO BLANCO	ACERO BARNIZADO
GRANIT BLANC	ACIER THERMOLAQUÉ



P. 229

FINISHING / FINITURE / ACABADOS / FINITIONS:



QUINTA IRON

BELLITALIA DESIGN

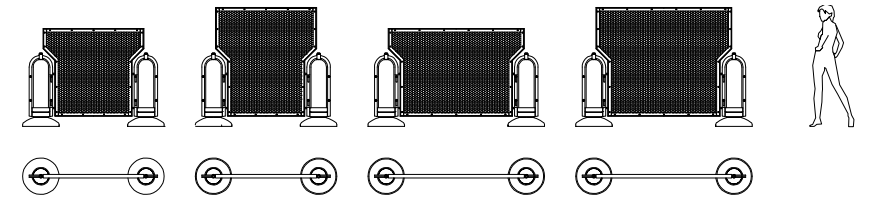

L 2000 mm
W 520 mm
H 1700 mm
348 kg

L 1500 mm
W 520 mm
H 1700 mm
332 kg

L 2000 mm
W 520 mm
H 1400 mm
338 kg

L 1500 mm
W 520 mm
H 1400 mm
320 kg



MATERIALS / MATERIALI / MATERIALES / MATÉRIAUX:

WHITE GRANITE	POWDER COATED STEEL
GRANITO BIANCO	ACCIAIO VERNICIATO
GRANITO BLANCO	ACERO BARNIZADO
GRANIT BLANC	ACIER THERMOLAQUÉ



P. 229

FINISHING / FINITURE / ACABADOS / FINITIONS:



QUINTA WOOD

BELLITALIA DESIGN

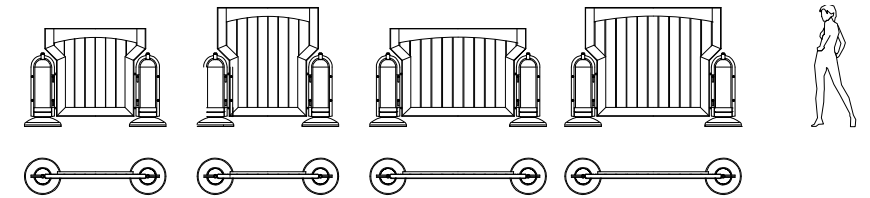

L 2000 mm
W 520 mm
H 1700 mm
320 kg

L 1500 mm
W 520 mm
H 1700 mm
310 kg

L 2000 mm
W 520 mm
H 1400 mm
338 kg

L 1500 mm
W 520 mm
H 1400 mm
328 kg

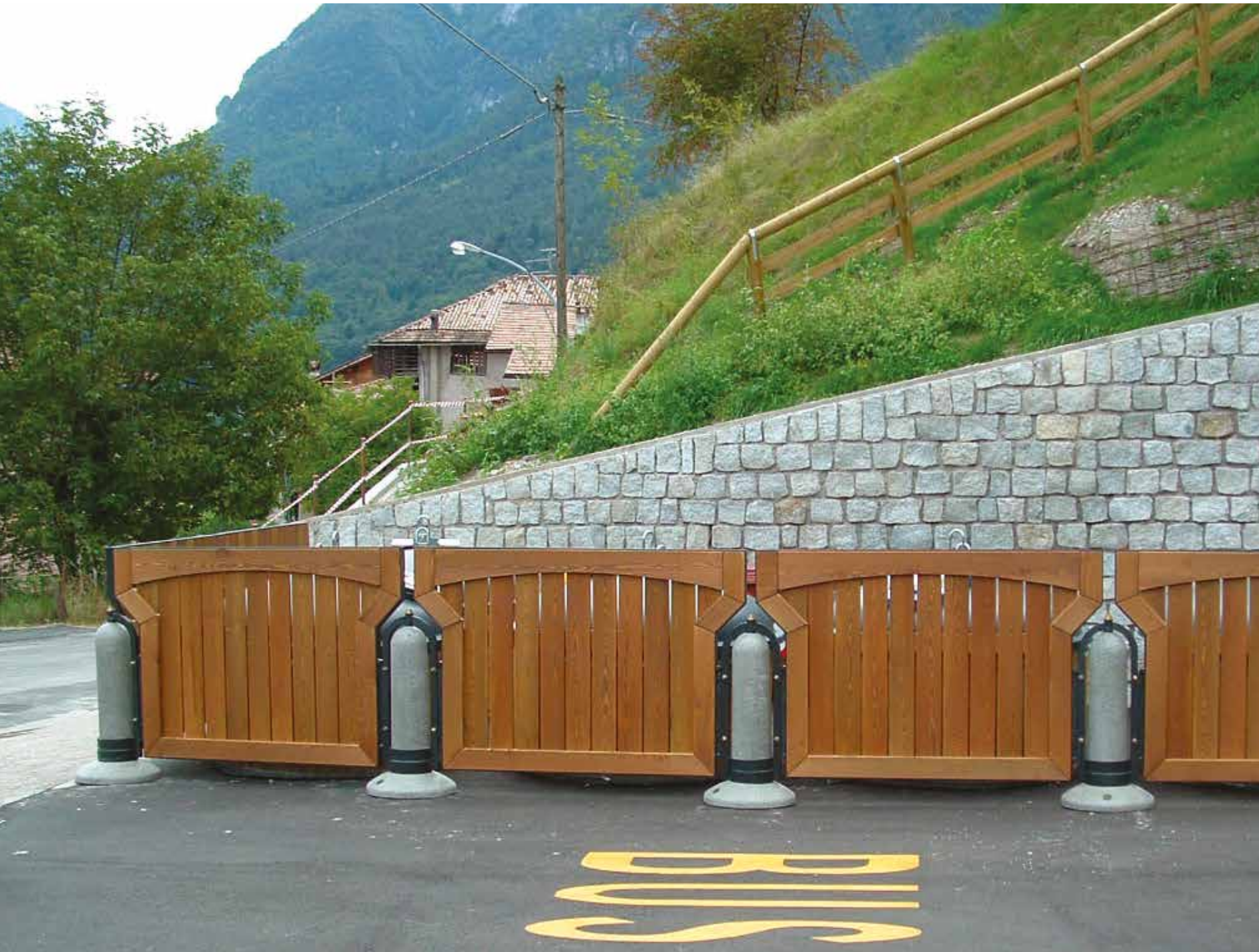

MATERIALS / MATERIALI / MATERIALES / MATÉRIAUX:

WHITE GRANITE	WOOD
GRANITO BIANCO	LEGNO
GRANITO BLANCO	MADERA
GRANIT BLANC	BOIS



FINISHING / FINITURE / ACABADOS / FINITIONS:





SHELTERS
PENSILINE
MARQUESINAS
ABRIS

MAGNUM EVOLUTION S - L

BELLITALIA DESIGN



MAGNUM EVOLUTION S - L

BELLITALIA DESIGN

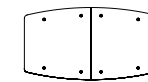
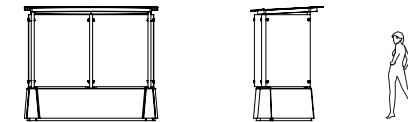

MAGNUM EVOLUTION S

L 2687 mm
W 1469 mm
H 2300 mm
1611 kg

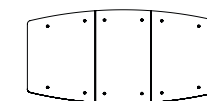
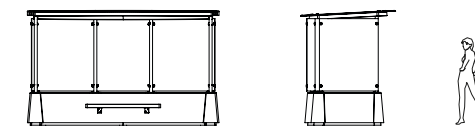

MAGNUM EVOLUTION L

L 3839 mm
W 1897 mm
H 2300 mm
2238 kg



MAGNUM EVOLUTION S - L

BELLITALIA DESIGN



MATERIALS / MATERIALI / MATERIALES / MATÉRIAUX:

NATURAL MARBLE STONES
PIETRE DI MARMO NATURALI
PIEDRAS DE MÁRMOL NATURAL
PIERRES DE MARBRE NATURELLES

GALVANIZED STEEL
ACCIAIO ZINCATO
ACERO GALVANIZADO
ACIER GALVANISÉ



FINISHING / FINITURE / ACABADOS / FINITIONS:



ACCESSORIES / ACCESSORI / ACCESORIOS / ACCESSOIRES:



MAGNUM TRANSPARENT
S - L
BELLITALIA DESIGN

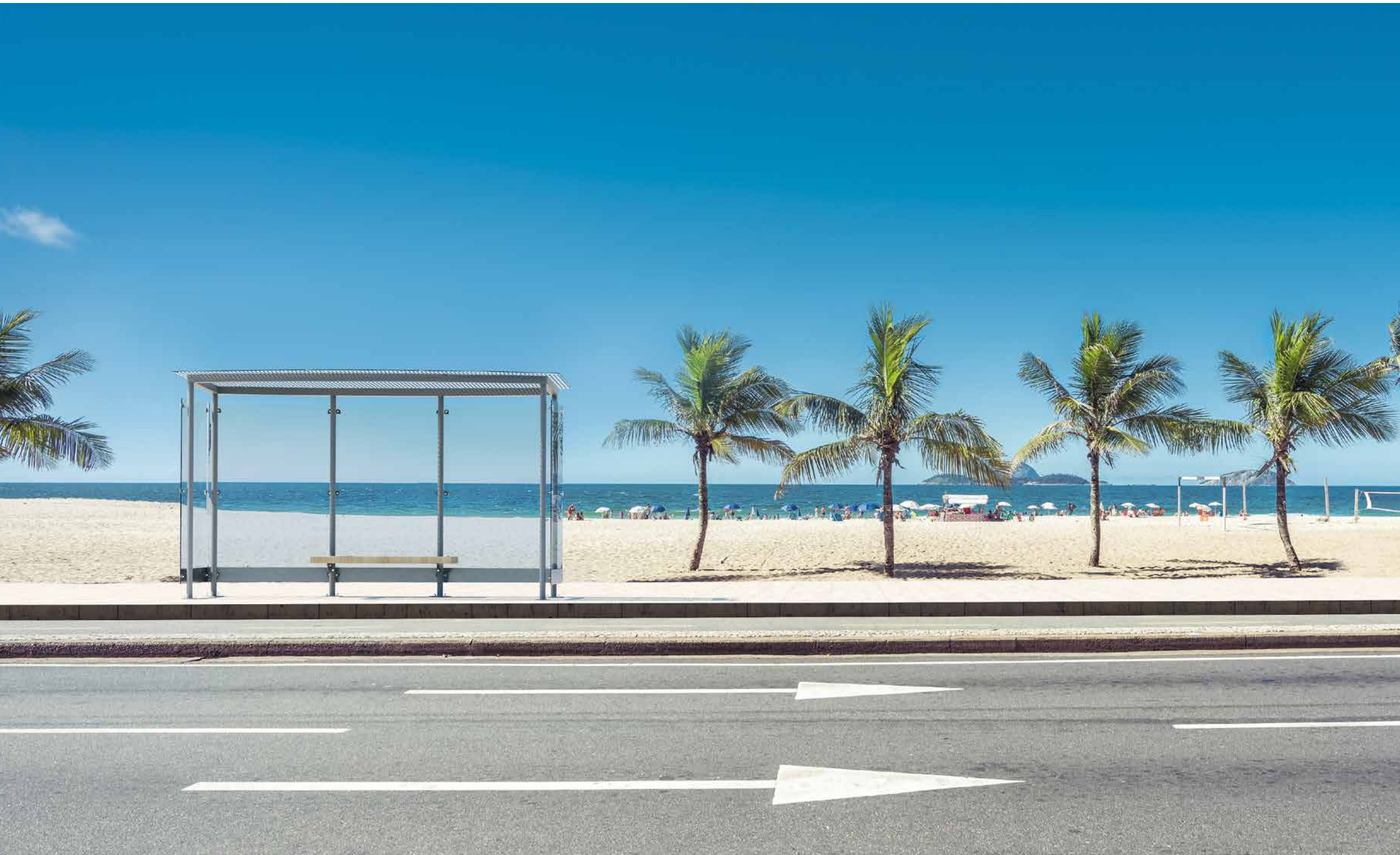

MAGNUM TRANSPARENT S - L

BELLITALIA DESIGN



MAGNUM TRANSPARENT S - L

BELLITALIA DESIGN

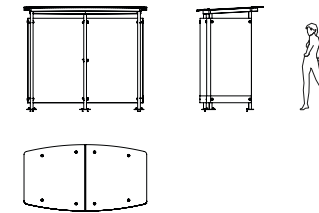

MAGNUM TRASPARENT S

L 2687 mm
W 1469 mm
H 2255 mm
446 kg

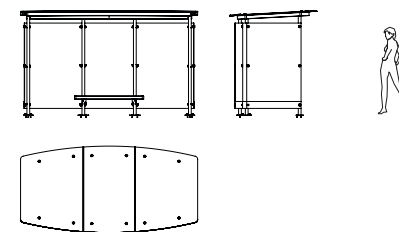

MAGNUM TRASPARENT L

L 3839 mm
W 1897 mm
H 2269 mm
603 kg

MAGNUM TRANSPARENT

S - L

BELLITALIA DESIGN



MATERIALS / MATERIALI / MATERIALES / MATÉRIAUX:

GALVANIZED STEEL
ACCIAIO ZINCATO
ACERO GALVANIZADO
ACIER GALVANISÉ



FINISHING / FINITURE / ACABADOS / FINITIONS:



ACCESSORIES / ACCESSORI / ACCESORIOS / ACCESSOIRES:





NEVE

BELLITALIA DESIGN

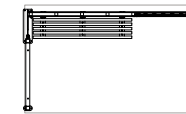
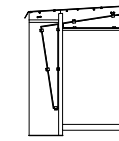
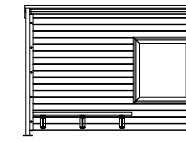

L 3681 mm
W 2057 mm
H 2627 mm
h 2515 mm
1160 kg



MATERIALS / MATERIALI / MATERIALES / MATÉRIAUX:

GALVANIZED STEEL
ACCIAIO ZINCATO
ACERO GALVANIZADO
ACIER GALVANISÉ

WOOD
LEGNO
MADERA
BOIS



FINISHING / FINITURE / ACABADOS / FINITIONS:



ACCESSORIES / ACCESSORI / ACCESORIOS / ACCESSOIRES:





FOUNTAINS
FONTANE
FUENTES
FONTAINES

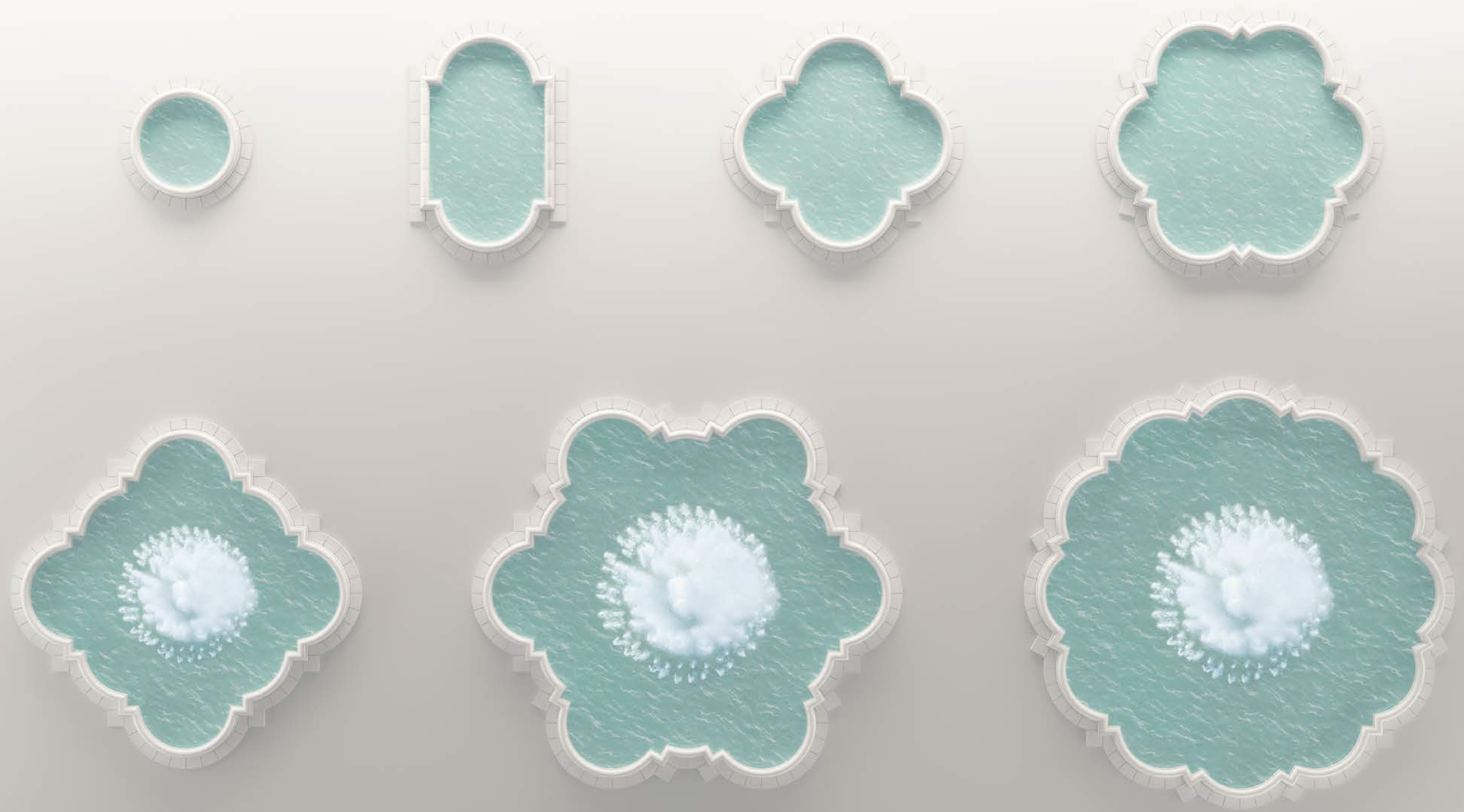



ASOLA

BELLITALIA DESIGN



CURVED
PLATE



LINEAR
PLATE



ANGULAR
PLATE

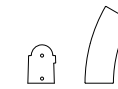

CURVED
ASHLAR



RIGHT
ANGLE
ASHLAR



LEFT
ANGLE
ASHLAR



LINEAR
ASHLAR

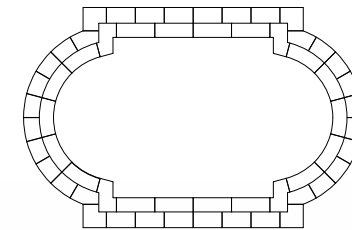

L 8840 mm
W 5740 mm
H 500 mm
11283 kg

MATERIALS / MATERIALI / MATERIALES / MATÉRIAUX:

NATURAL MARBLE STONES
PIETRE DI MARMMO NATURALI
PIEDRAS DE MÁRMOL NATURAL
PIERRES DE MARBRE NATURELLES

WHITE GRANITE
GRANITO BIANCO
GRANITO BLANCO
GRANIT BLANC



FINISHING / FINITURE / ACABADOS / FINITIONS:



ACCESSORIES / ACCESSORI / ACCESORIOS / ACCESSOIRES:



CALLA

BELLITALIA DESIGN

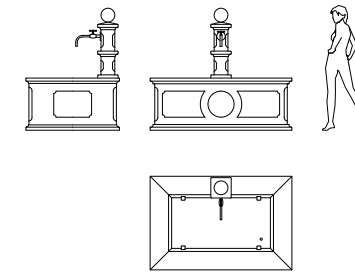

L 1847 mm
W 1220 mm
H 1591 mm
2000 kg



MATERIALS / MATERIALI / MATERIALES / MATÉRIAUX:

NATURAL MARBLE STONES
PIETRE DI MARMO NATURALI
PIEDRAS DE MÁRMOL NATURAL
PIERRES DE MARBRE NATURELLES

WHITE GRANITE
GRANITO BIANCO
GRANITO BLANCO
GRANIT BLANC

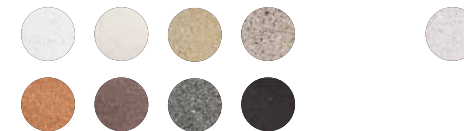

FINISHING / FINITURE / ACABADOS / FINITIONS:



ACCESSORIES / ACCESSORI / ACCESORIOS / ACCESSOIRES:



GIRASOLE

BELLITALIA DESIGN





GIRASOLE

BELLITALIA DESIGN



CURVED
PLATE

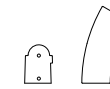

CURVED
ASHLAR

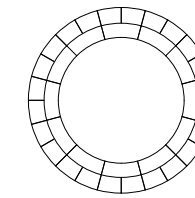

Ø 4840 mm
H 500 mm
5568 kg

MATERIALS / MATERIALI / MATERIALES / MATÉRIAUX:

NATURAL MARBLE STONES
PIETRE DI MARMO NATURALI
PIEDRAS DE MÁRMOL NATURAL
PIERRES DE MARBRE NATURELLES

WHITE GRANITE
GRANITO BIANCO
GRANITO BLANCO
GRANIT BLANC



FINISHING / FINITURE / ACABADOS / FINITIONS:



ACCESSORIES / ACCESSORI / ACCESORIOS / ACCESSOIRES:





MARGHERITA

BELLITALIA DESIGN

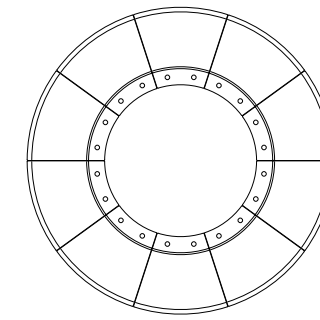
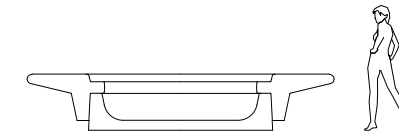

Ø 4000 mm
H 502 mm
8337 kg

MATERIALS / MATERIALI / MATERIALES / MATÉRIAUX:

NATURAL MARBLE STONES	WHITE GRANITE
PIETRE DI MARMO NATURALI	GRANITO BIANCO
PIEDRAS DE MÁRMOL NATURAL	GRANITO BLANCO
PIERRES DE MARBRE NATURELLES	GRANIT BLANC

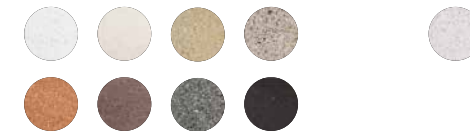

FINISHING / FINITURE / ACABADOS / FINITIONS:

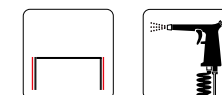
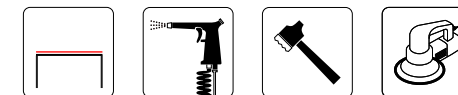

ACCESSORIES / ACCESSORI / ACCESORIOS / ACCESSOIRES:

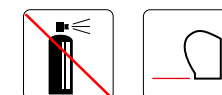

ORCHIDEA

BELLITALIA DESIGN





ORCHIDEA

BELLITALIA DESIGN

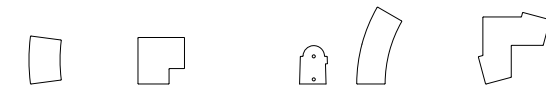

CURVED
PLATE

ANGULAR
PLATE

CURVED
ASHLAR

POINTED
ASHLAR

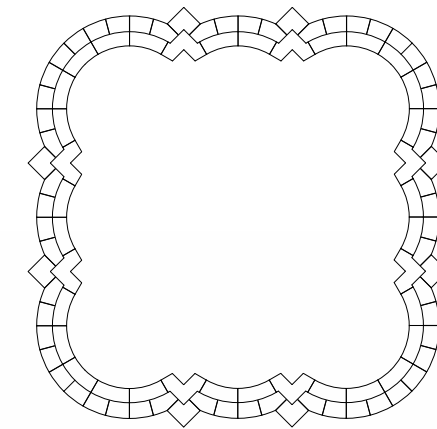

L 12840 mm
W 12840 mm
H 500 mm
18060 kg

MATERIALS / MATERIALI / MATERIALES / MATÉRIAUX:

NATURAL MARBLE STONES
PIETRE DI MARMO NATURALI
PIEDRAS DE MÁRMOL NATURAL
PIERRES DE MARBRE NATURELLES

WHITE GRANITE
GRANITO BIANCO
GRANITO BLANCO
GRANIT BLANC

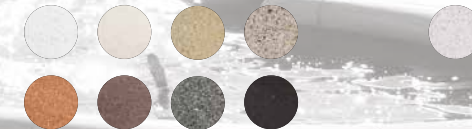

FINISHING / FINITURE / ACABADOS / FINITIONS:



ACCESSORIES / ACCESSORI / ACCESORIOS / ACCESSOIRES:

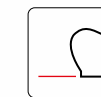



QUADRIFOGLIO

BELLITALIA DESIGN



CURVED
PLATE



ANGULAR
PLATE



CURVED
ASHLAR



POINTED
ASHLAR

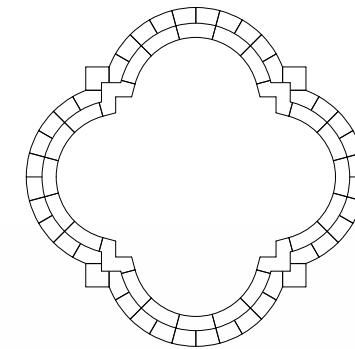

L 8840 mm
W 8800 mm
H 500 mm
11576 kg

MATERIALS / MATERIALI / MATERIALES / MATÉRIAUX:

NATURAL MARBLE STONES
PIETRE DI MARMO NATURALI
PIEDRAS DE MÁRMOL NATURAL
PIERRES DE MARBRE NATURELLES

WHITE GRANITE
GRANITO BIANCO
GRANITO BLANCO
GRANIT BLANC

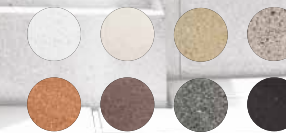

FINISHING / FINITURE / ACABADOS / FINITIONS:



ACCESSORIES / ACCESSORI / ACCESORIOS / ACCESSOIRES:



SORAGA

BELLITALIA DESIGN





SORAGA

BELLITALIA DESIGN

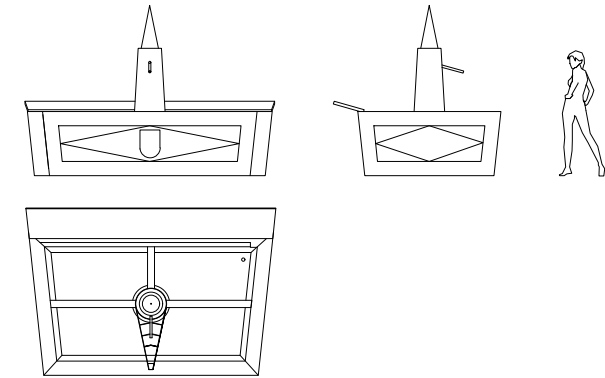

L 3498 mm
W 3225 mm
H 2345 mm
2386 kg

MATERIALS / MATERIALI / MATERIALES / MATÉRIAUX:

NATURAL MARBLE STONES
PIETRE DI MARMO NATURALI
PIEDRAS DE MÁRMOL NATURAL
PIERRES DE MARBRE NATURELLES

WHITE GRANITE
GRANITO BIANCO
GRANITO BLANCO
GRANIT BLANC



FINISHING / FINITURE / ACABADOS / FINITIONS:



ACCESSORIES / ACCESSORI / ACCESORIOS / ACCESSOIRES:



The image shows a close-up of cork material, likely from a wine barrel, with a dark, circular opening visible in the background. The cork has a characteristic porous, cellular structure. The text is overlaid on the right side of the image.

MATERIALS AND TECHNICAL DETAILS
MATERIALI E DETTAGLI TECNICI
MATERIALES Y DETALLES TÉCNICOS
MATÉRIAUX ET DÉTAILS TECHNIQUES

GENERAL REQUIREMENTS APPLICABLE TO ALL BELLITALIA®'S PRODUCTS IN ANY MATERIAL

Upon receipt of the goods, where it is not possible to place and/or install them within a few days, they must always be removed from plastic (nylon) packaging to allow ventilation and prevent the formation of condensation that can irreparably damage the product. Particularly, the packaging should always be removed immediately if it is not possible to keep the goods in a covered place protected from sunlight.

Warning: treatments and materials described in this catalogue are those in use on the same date of release of the catalogue. Bellitalia® reserves the right to make changes and/or updates and/or improvements to treatments set forth herein to conform to its production needs and/or implementation of the quality of the final product. Bellitalia® also reserves the right to delete and/or replace the materials displayed at their own discretion within the catalogue, as well as insert new materials. Any significant changes will be shown on the Bellitalia® website (www.bellitalia.net) and/or supplied by sales info or similar ways. The latest updated information on materials will be valid in all cases.

NOTES ON PRODUCTS ON AGGREGATES OF NATURAL MARBLE STONES, GREY CONCRETE AND WHITE GRANITE

Slight color and finishing variations (micro-cracks, circle, oxide arising, shades differences and surface coat etc.) are natural phenomenon due to the production and maturation phase: no claims or requests can be raised for color variations connected to materials nature and to atmospheric conditions during production and maturation phase. In no case it shall be intended as nonconformity of the product.

PRESCRIZIONI GENERALI VALIDE PER TUTTI I PRODOTTI BELLITALIA® IN QUALSIASI MATERIALE

Al ricevimento della merce, qualora non sia possibile procedere entro pochi giorni al suo posizionamento e/o al montaggio, questa deve essere tassativamente liberata dal materiale plastico (nylon) d'imballo, per consentire l'areazione ed impedire la formazione di condensa che può danneggiare irrimediabilmente i prodotti. In particolar modo, l'imballo va sempre rimosso con la massima tempestività nel caso in cui non sia possibile mantenere la merce in luogo coperto dai raggi del sole.

Attenzione: I trattamenti e i materiali descritti nel presente catalogo sono quelli in uso alla data di stampa dello stesso. Bellitalia® si riserva di apportare modifiche e/o aggiornamenti e/o migliorie ai trattamenti qui indicati in base alle proprie esigenze produttive e/o di implementazione della qualità del prodotto finale. Altresì Bellitalia® si riserva di eliminare e/o sostituire a propria discrezione i materiali indicati nel catalogo e/o di introdurre di nuovi. Eventuali rilevanti variazioni verranno riportate sul sito Bellitalia® (www.bellitalia.net) e/o comunicate tramite sales info o mezzi simili. In ogni caso, sarà da ritenersi valido il materiale informativo di più recente aggiornamento.

NOTE SUI PRODOTTI IN AGGREGATI DI PIETRE DI MARMO, CEMENTO GRIGIO E GRANITO BIANCO

Le leggere variazioni di colore di finitura (microfessurazioni, aureole, risalita di ossidi, differenze di riflessi e di stato delle superfici, ecc.) sono fenomeni naturali della fase di produzione e di maturazione del prodotto. I campioni di colore sono indicativi: non si potrà addire a contestazioni o richiesta di danni per le variazioni di colore che sono dovute alla natura dei materiali e alle condizioni atmosferiche durante la fase di produzione e di maturazione del prodotto. IN ogni caso essi non costituiscono difetto di conformità.

PRESCRIPCIONES GENERALES VÁLIDAS PARA TODOS LOS PRODUCTOS BELLITALIA® EN CUALQUIER MATERIAL

A la recepción del material, en los casos en que no sea posible en un plazo de pocos días la instalación y/o montaje de los productos, estos deberán obligatoriamente desembalarse para permitir que se aireen e impedir la condensación que podría dañar irreversiblemente el material. En particular, el embalaje siempre deberá retirarse con la máxima prioridad en caso que no sea posible resguardar el material de los rayos solares.

Advertencia: Los tratamientos y los materiales descritos en este catálogo son aquellos en uso a la fecha de su publicación. Bellitalia® se reserva el derecho de hacer modificaciones y/o actualizaciones y/o mejoras a los tratamientos indicados en el presente documento según sus exigencias productivas y/o de implementación de la calidad del producto final. Asimismo, Bellitalia® se reserva el derecho de eliminar y/o sustituir a su discreción los materiales aquí indicados o de introducir nuevos. Las eventuales variaciones significativas serán reportadas en el sitio web de Bellitalia® (www.bellitalia.net) y/o comunicadas a través informaciones de venta o medios similares. En todo caso, debe considerarse válido el material informativo de última actualización.

NOTAS SOBRE PRODUCTOS EN CONGLOMERADO DE PIEDRA DE MÁRMOL, HORMIGÓN GRIS Y GRANITO BLANCO

Ligeras variaciones de color y acabados (micro-fisuras, subida de óxidos, diferencias de reflejos y de estado de las superficies, etc.) son fenómenos naturales debidos a la fase de producción y de maduración del producto. Las muestras de color sono meramente ilustrativas: no se podrán presentar reclamaciones de daños con referencia a variaciones de color debidas a la naturaleza de los materiales y a las condiciones atmosféricas durante la fase de producción y maduración del producto. Lo anterior no constituye defecto de conformidad.

RECOMMENDATIONS GENERALES APPLICABLES A TOUS LES PRODUITS BELLITALIA® QUEL QUE SOIT LE MATERIAU

Lors de la réception de la marchandise, si la mise en oeuvre ou le montage ne peuvent pas être réalisés rapidement, les produits doivent impérativement être débarrassés de leurs emballages plastiques (nylon) afin de permettre l'aération et d'éviter la condensation qui peut nuire irrémédiablement à la qualité du matériel. Les emballages doivent impérativement être retirés dans le cas où le stockage des produits n'est pas possible dans un lieu couvert à l'abri du soleil.

Attention: Les traitements et les matériaux décrits dans ce catalogue sont ceux utilisés à sa date de publication. Bellitalia® se réserve le droit d'apporter des modifications et/ou mises à jour et/ou améliorations des traitements indiqués en fonction des exigences de production et/ou afin d'améliorer la qualité du produit final. Bellitalia® se réserve également le droit de supprimer et/ou remplacer à sa propre convenance les matériaux indiqués dans le catalogue et/ou introduire de nouveaux. Toute modification significative sera affichée sur le site Bellitalia® (www.bellitalia.net) et/ou fournis par le réseau de ventes. Dans tous les cas, seule l'information la plus récente sera considérée comme valable.

REMARQUE SUR LES PRODUITS EN AGRÉGAT DE PIERRES DE MARBRE NATUREL, CIMENT GRIS ET GRANIT BLANC

Les légères nuances de couleurs et de finitions (microfissures, auréoles, remontées d'oxydes, différences de reflets et d'état des surfaces, etc.) sont des phénomènes naturels se produisant lors de la phase de production et de maturation du produit. Les échantillons de couleur sont indicatifs: aucune contestation ni aucune demande de dédommagement pour les nuances de couleur dues aux conditions atmosphériques lors de la phase de production et de maturation du produit ne seront acceptées. Dans tous les cas, ces phénomènes ne représentent pas des défauts de conformité.

AGGREGATE OF NATURAL MARBLE STONES

AGGREGATO DI PIETRE DI MARMO NATURALI

CONGLOMERADO DE PIEDRAS DE MÁRMOL

AGRÉGAT DE PIERRES DE MARBRE NATUREL

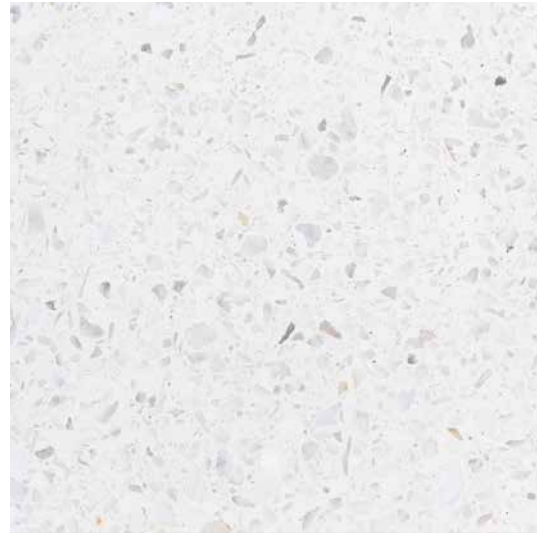

BIANCO CARRARA

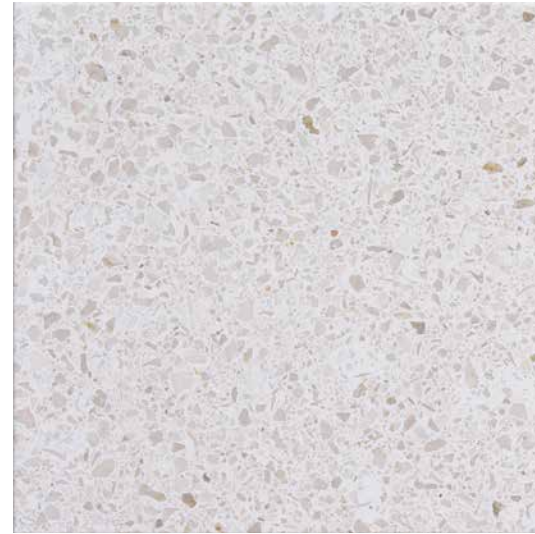

BOTTICINO

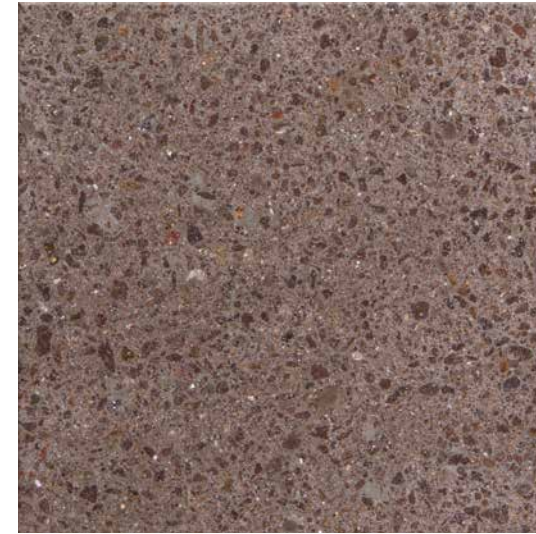

PORFIDO

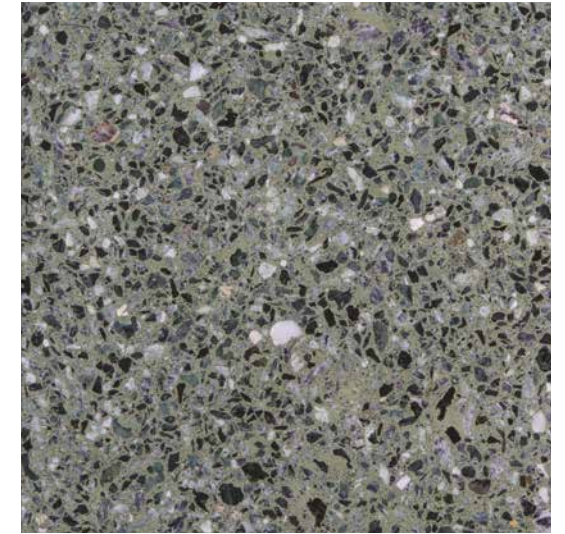

VERDE ALPI

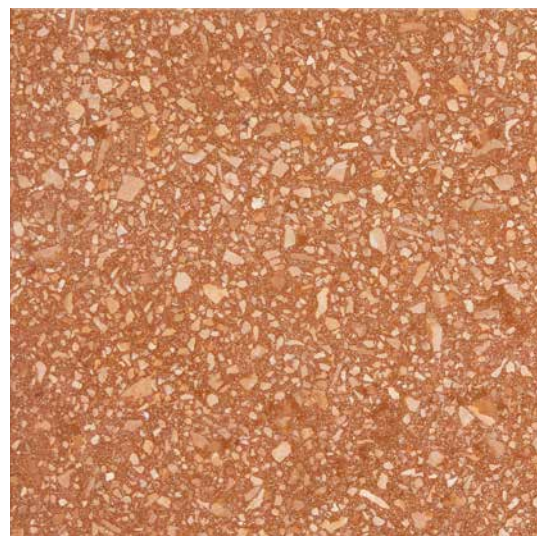

ROSSO VERONA

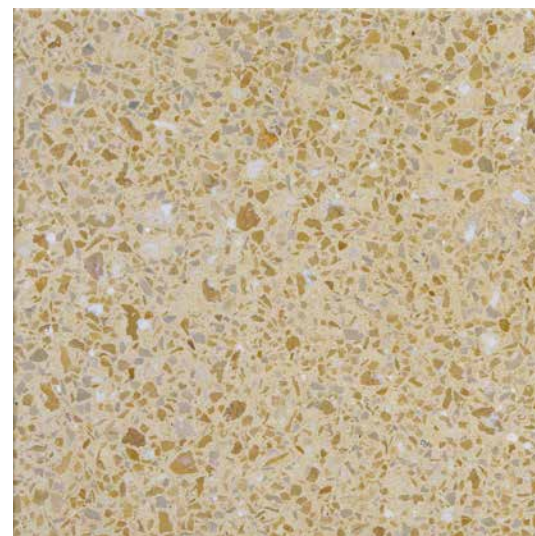

GIALLO MORI

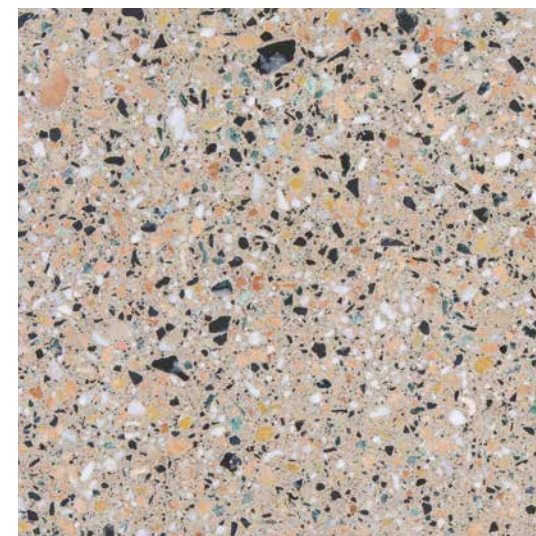

VENEZIANO



NERO EBANO

Features: to produce the marble stone conglomerate, white portland cement is mixed with inert materials of various size from Italian marble quarries. The dust from the same natural stone gives the products its characteristic final colour.

Caratteristiche: per realizzare il conglomerato di pietre di marmo si utilizzano cementi bianchi portland e inerti di varie pezzature provenienti dalle cave italiane del marmo. È la polvere stessa della pietra naturale a conferire al manufatto il caratteristico colore finale.

Características: para realizar el conglomerado de las piedras de mármol, utilizamos cemento blanco portland y árido de diferentes tamaños de las canteras de mármol italiano. El polvo de la piedra natural es el que aporta el característico color final.

Caractéristiques: pour réaliser le conglomerat des pierres de marbre, nous utilisons des ciments blancs Portland et inertes de différentes dimensions provenant des carrières de marbre italien. C'est la poudre de la pierre naturelle qui donne la caractéristique couleur finale.

GREY CONCRETE
CEMENTO GRIGIO
HORMIGÓN GRIS
CIMENT GRIS



Features: to produce grey concrete, portland cement is used with inert materials from local quarries.

Caratteristiche: per realizzare il calcestruzzo grigio, si utilizzano cementi portland e inerti provenienti dalle cave locali.

Características: para la realización del hormigón gris, se utilizan cemento portland y áridos procedentes de las canteras locales.

Caractéristiques: pour produire du béton gris, le ciment portland est utilisé avec des minéraux inertes des carrières locales.

WHITE GRANITE
GRANITO BIANCO
GRANITO BLANCO
GRANIT BLANC

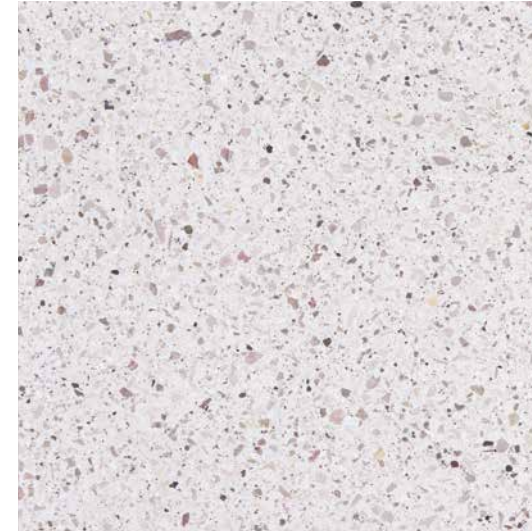

Features: to produce white granite, white portland cement is used with white inert materials from local quarries.

Caratteristiche: per realizzare il granito bianco si utilizzano cementi bianchi portland e inerti bianchi provenienti dalle cave locali.

Características: se utiliza granito blanco, portland blanco y áridos blancos de canteras locales.

Caractéristiques: pour faire du granit blanc, on utilise des agrégats blancs de Portland et blancs provenant de carrières locales.

FINISHING AND TREATMENTS

FINITURE E TRATTAMENTI

ACABADOS Y TRATAMIENTOS

FINITIONS ET TRAITEMENTS



Polishing: the material is polished manually, or mechanically with robotic machines, to remove the surface layer and give the product an elegant, shiny and bright look.

Levigatura: il manufatto viene levigato manualmente o meccanicamente con macchinari robotizzati che rimuovono lo strato superficiale del materiale per conferire al prodotto un aspetto elegante, lucido e brillante.

Lijado: el producto se somete a un lijado manual o mecánico con máquinas robóticas que eliminan la capa superficial del material para darle al producto un aspecto elegante, lúcido y brillante.

Ponçage: le produit est soumis à un ponçage manuel ou mécanique avec des machines robotisées qui enlèvent la couche superficielle du matériau pour donner au produit l'aspect brillant et élégant.



Bush-hammering: the bush-hammered finishing breaks the surface stones, giving the product a rough appearance that brings out the best of the fine aggregates that compose it.

Bocciardatura: la finitura martellinata rompe superficialmente le pietre, donando al manufatto un aspetto ruvido che fa risaltare al massimo gli inerti pregiati che lo compongono.

Abujardado: el acabado martillado rompe superficialmente las piedras, dando al producto una apariencia áspera que resalta los agregados preciosos que lo componen.

Bouchardage: la finition martelée brise superficiellement les pierres, donnant au produit un aspect rugueux qui fait ressortir les précieux agrégats qui le composent.



Sandblasting: sandblasting is a mechanical process that uses a powerful jet of compressed air and silica sand to remove the superficial material bringing out the background stones.

Sabbiatura: la sabbiatura è una lavorazione meccanica che utilizza un potente getto di aria compressa e sabbie silicee per eseguire un'asportazione superficiale di materiale che fa risaltare le pietre di sottofondo.

Arenado: es un proceso mecánico que proyecta un chorro de aire a alta presión con arena de sílice para conseguir un decapado superficial y resaltar la piedra de fondo.

Sablage: le sablage est une action mécanique de nettoyage des surfaces avec du sable projeté à grande vitesse, ce qui donne à la surface un aspect uniforme naturel.

STEEL
ACCIAIO
ACERO
ACIER

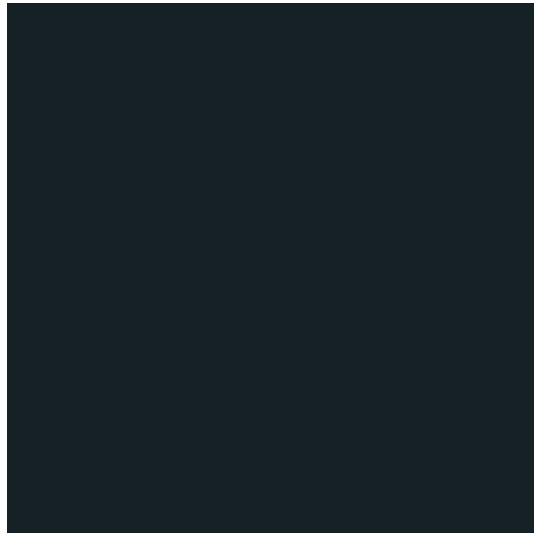

Coloration: Bellitalia® uses P.P. paints that provide a textured opaque finish and, in the case of some artifacts, a lucid finish.

Colorazioni: Bellitalia® utilizza vernici P.P. con finitura opaca raggrinzante e, solo su alcuni articoli, con finitura lucida.

Colores: Bellitalia® usa pinturas PP con acabado mate y, solo en algunos artículos, con acabado brillante.

Couleurs: Bellitalia® utilise des peintures PP à finition mate ridée et seulement sur certains articles à finition brillante.

UPON REQUEST
SU RICHIESTA
BAJO PEDIDO
SUR DEMANDE



RAL 1013



RAL 1021



RAL 1028



RAL 1036



RAL 2002



RAL 3000



RAL 3003



RAL 5010



RAL 6005



RAL 6029



RAL 7001



RAL 7012



RAL 7016

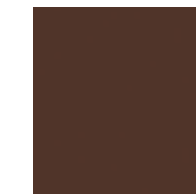

RAL 8017



RAL 9005



RAL 7021



RAL 9006



RAL 9007

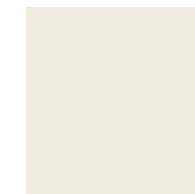

RAL 9010



RAL 9022

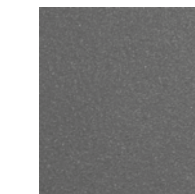

GREY

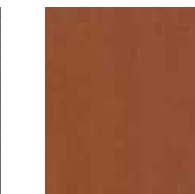

CORTEN COLOR

FINISHING AND TREATMENTS

FINITURE E TRATTAMENTI

ACABADOS Y TRATAMIENTOS

FINITIONS ET TRAITEMENTS

Treatments: for painted steel products, Bellitalia® uses the most suitable galvanizing system; depending on the product thickness and/or manufacturing process, the system used will vary between:

- hot-dip galvanization
- sendzimir galvanization
- electrogalvanization
- cathoresis

Trattamenti: per i prodotti in acciaio verniciato Bellitalia® utilizza, di volta in volta, il sistema di zincatura più adatto in base alle caratteristiche di spessore e/o processo di lavorazione alternativamente tra:

- zincatura a caldo
- zincatura sendzimir
- zincatura elettrolitica a freddo
- cataforesi

Tratamientos: para los aceros, Bellitalia® utiliza el sistema de galvanización más adecuado en función de las características del producto, el espesor y/o el proceso de fabricación. Estos procesos alternativos son:

- galvanizado en caliente
- galvanización Sendzimir
- galvanización electrolítica en frío
- cataforesis

Traitements: Bellitalia® utilise le zincage pour les produits en acier peint, selon l'épaisseur et/ou le processus de fabrication:

- zincage à chaud
- zincage sendzimir
- zincage électrolytique à froid
- cathorèse

COPPER

RAME

COBRE

CUIVRE

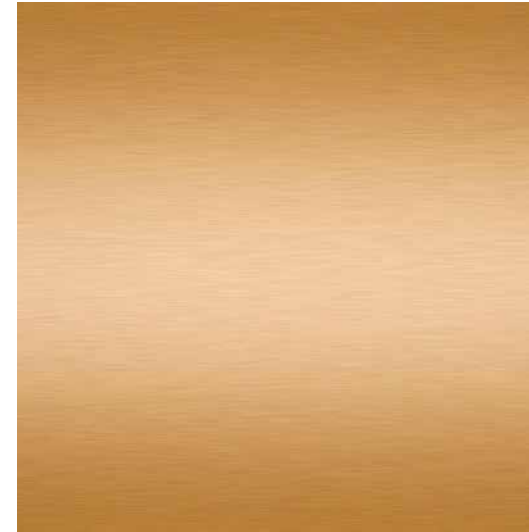

Features: copper is used for decorative bands or to make some parts of the products, and consists of pure copper sheets.

Caratteristiche: il rame utilizzato per le fasce decorative oppure per realizzare alcune parti dei prodotti è costituito da fogli di rame puro.

Características: el cobre utilizado para las bandas decorativas o para realizar algunas partes de los productos está constituido por hojas de cobre pura.

Caractéristiques: le cuivre utilisé pour les bandes décoratives ou pour réaliser certaines parties des produits est constitué par des feuilles de cuivre pur.

FINISHING AND TREATMENTS

FINITURE E TRATTAMENTI

ACABADOS Y TRATAMIENTOS

FINITIONS ET TRAITEMENTS

Treatment: copper band are painted with transparent protective paints, while the constituent parts of the copper products are burnished and subsequently painted.

Trattamento: le fasce decorative vengono verniciate con pitture protettive trasparenti, mentre le parti costitutive degli articoli in rame vengono bruniti e successivamente verniciate.

Tratamiento: las bandas decorativas se barnizan, mientras que las partes que componen los elementos de cobre se bruñen primero y luego se barnizan.

Traitements: les bandes décoratives sont recouvertes de peinture protectrice transparente, tandis que les articles en cuivre sont brunis et peints ensuite.

STAINLESS STEEL

ACCIAIO INOX

ACERO INOX

ACIER INOX



Features: Bellitalia® uses stainless steel AISI 303, 304, 304L, 316 or 316L.

Caratteristiche: Bellitalia® utilizza acciaio inox AISI 303, 304, 304L, 316 o 316L.

Características: Bellitalia® utiliza acero inoxidable AISI 303, 304, 304L, 316 o 316L.

Caractéristiques: Bellitalia® utilise l'acier inox AISI 303, 304, 304L, 316 ou 316L.

FINISHING AND TREATMENTS

FINITURE E TRATTAMENTI

ACABADOS Y TRATAMIENTOS

FINITIONS ET TRAITEMENTS

Treatments:

- satinizing and electropolishing

On selected products the electropolishing is on request and subject to extra-charges.

Warning: In case of installation of stainless steel products in areas characterized by salty air (e.g. near the sea) or by severe pollution, Bellitalia® recommends to request electropolishing treatment.

This treatment improves stainless steel resistance to corrosion.

Trattamenti:

- satinatura e elettrolucidatura

Su alcuni prodotti selezionati, l'elettrolucidatura è su richiesta e soggetta a sovrapprezzo.

Attenzione: In caso di installazione dei manufatti in acciaio inox in zone caratterizzate da aria salina (es. in vicinanza del mare) o da forte inquinamento atmosferico. Bellitalia® raccomanda di richiedere sempre il trattamento di elettrolucidatura.

Tale trattamento migliora la resistenza alla corrosione dell'acciaio inox.

Tratamientos:

- satinado y electropulidura

En algunos productos seleccionados, el electropulido es a pedido y con coste adicional.

Advertencia: para productos en acero inox instalados en áreas con aire salino (por ejemplo en proximidad del mar) o con fuerte contaminación, Bellitalia® recomienda pedir siempre el tratamiento electropulido.

Dicho tratamiento mejora la resistencia a corrosión del acero inox.

Traitements:

- satinage et électropolissage

Un traitement d'électropolissage peut être effectué, sur demande et avec un supplément de prix.

Attention: Si les produits doivent être positionnés dans un environnement salin (ex: à proximité de la mer) ou fortement pollué, Bellitalia® recommande de toujours réclamer le traitement d'electropolissage.

Ce traitement améliore la résistance à la corrosion des produits manufacturés en acier inox.

WOOD
LEGNO
MADERA
BOIS



OKUMÈ / OKUMÈ / OKUMÈ / OKUMÈ



PINO / PINO / PINO / PINO



HARDWOOD / LEGNO ESOTICO

Wood is a natural material and, as such, every table is different in terms of pattern and tonality and can have natural imperfections. When weather conditions change (cold/warm, dry/wet), the wood moisture changes and the material can increase or decrease in volume, causing cracks and fissures. This is natural. Bellitalia® uses only high-quality or highly resilient woods, chosen for their characteristics and durability in the outdoor environment. The following types of woods are offered to meet a range of individual customer preferences:

HARDWOOD (Angelim Amargoso, Iroko, Movingui, Basralocus).

Bellitalia® reserves the right to select the most suitable hardwood depending on the product's needs and on the market availability at any given time.

Wood products come ready-supplied with pigmented water-based impregnator (see "Finishing").

If you prefer not to receive pigmented water-based impregnator with your order, please let us know. FSC wood can be provided on request, and may result in a longer delivery time.

PINE

Pine wood is solid or engineered, depending on the structure and section of the wood used. The wood comes ready-supplied with pigmented water-based impregnator (see "Finishing").

OKUMÈ

All okumè wood purchases come ready-supplied with water-based paint (see "Finishing").

UPON REQUEST

FSC - CERTIFIED LARCH

Larch wood is solid or engineered, depending on the structure and section of the wood used. The wood comes ready-supplied with pigmented water-based impregnator (see "Finishing").

For the type of wood used for each product please see the current pricelist.

Il legno è un materiale naturale e come tale ogni tavola si differenzia per fiammature, tonalità e può avere delle imperfezioni naturali. Al variare delle condizioni atmosferiche (caldo/freddo, secco/umido) l'umidità del legno varierà e il legno potrebbe aumentare o diminuire di volume, comportando crepe e fessure. Tutto ciò è naturale.

Bellitalia® impiega solamente legni pregiati e altamente resistenti, scelti in base alle loro caratteristiche per essere durevoli all'esterno. A seconda delle diverse esigenze del cliente vengono proposti le seguenti tipologie di legno:

LEGNO DURO (Angelim Amargoso, Iroko, Movingui, Basralocus).

Bellitalia® si riserva di selezionare di volta in volta i legni duri più adatti alle esigenze di prodotto e/o progetto e secondo le disponibilità del mercato.

Il legno viene sempre fornito con impregnante a base acqua pigmentato (vedi voce "Finiture").

Su richiesta può essere fornito senza impregnante a base acqua pigmentato. Il legno FSC è fornito su richiesta e pertanto i tempi di consegna potrebbero estendersi.

PINO

Legno di pino massello o lamellare, a seconda del manufatto e della sezione di legno utilizzato. Il legno viene fornito sempre fornito con impregnante a base acqua pigmentato (vedi voce "Finiture").

OKUMÈ

Il legno viene sempre ed unicamente fornito con verniciatura a base d'acqua (vedi voce "Finiture").

SU RICHIESTA

LARICE FSC

Legno di larice massello o lamellare, a seconda del manufatto e della sezione di legno utilizzato. Il legno viene fornito sempre fornito con impregnante a base acqua pigmentato (vedi voce "Finiture").

Per la tipologia di legno utilizzata per ciascun prodotto prego vedere il listino prezzi corrente.

La madera es un material natural y, como tal, cada listón se diferencia por sus vetas, nudos y sus imperfecciones naturales. Con el cambio de las condiciones climáticas (frío/calor, seco/húmedo) el grado de humedad relativa de la madera varía y por ello aumenta y disminuye en volumen, lo que produce grietas y hendiduras. Todo esto es natural. Bellitalia® utiliza maderas tropicales y altamente resistentes, escogidas de acuerdo con sus características para que sean duraderas en el exterior. Dependiendo de las diferentes necesidades del cliente se proponen los siguientes tipos de madera de alta densidad:

MADERA DURA (Angelim Amargoso, Iroko, Movingui, Baralous)

Bellitalia® se reserva la selección de la madera dura cuando mejor se adapta a la exigencia del producto y del proyecto según disponibilidad del mercado.

La madera siempre se suministra con una imprimación a base de agua pigmentada (ver "Acabados").

Bajo pedido puede suministrarse natural sin imprimación. La madera FSC se suministra bajo pedido y por lo tanto los plazos de entrega pueden extenderse.

PINO

Madera de pino sólida o laminar, según la estructura y la sección de madera utilizada. La madera siempre se suministra con una impregnación a base de agua pigmentada (ver "Acabados").

OKUMÉ

La madera sólo se suministra con pintura a base de agua (ver "Acabados").

BAJO PEDIDO

LARICE FSC

Madera de larice sólida o laminar, según la estructura y la sección de madera utilizada. La madera siempre se suministra con una impregnación a base de agua pigmentada (ver "Acabados").

Para constatar el tipo de madera de cada producto, rogamos consultar el listado de precios.

Le bois en tant que matériau naturel présente des veines et des nuances qui ne sont pas des défauts. Avec les variations atmosphériques (chaleur/froid, sécheresse/humidité) le taux d'humidité sera variable et le bois pourrait gonfler ou se restreindre, ce qui produit des fissures et des entailles. Tout cela est naturel.

Bellitalia® emploie uniquement des bois de qualité et très résistants, choisis pour rester dehors longtemps.

Selon les exigences du client, différentes sortes de bois sont proposées:

BOIS DUR (Angelim Amargoso, Iroko, Movingui, Basralocus).

Bellitalia® décide à chaque production quels seront les bois durs les mieux adaptés aux produits et/ou aux projets, suivant la disponibilité sur le marché.

Le bois est toujours fourni avec un imprégnant coloré à base d'eau (voir "Finitions").

Sur demande, sans imprégnant coloré. Le bois FSC fourni sur demande sera donc livré avec un délai variable.

PIN

Pin massif ou en feuilles, selon le produit et la section du bois utilisé. Le bois est toujours fourni avec un imprégnant coloré à base d'eau (voir "Finitions").

OKOUME

Bois uniquement fourni avec peinture à l'eau (voir "Finitions").

SUR DEMANDE

MELEZE FSC

Mélèze massif ou en feuilles, selon le produit et la section du bois utilisé. Le bois est toujours fourni avec un imprégnant coloré à base d'eau (voir "Finitions").

Consulter les tarifs pour chaque produit selon le bois utilisé

FINISHING AND TREATMENTS

FINITURE E TRATTAMENTI

ACABADOS Y TRATAMIENTOS

FINITIONS ET TRAITEMENTS

A. PIGMENTED WATER-BASED IMPREGNATION:

The treatment involves an automatic brushing of the wood, followed by a coat of pigmented water based impregnating agent, applied by spray and distributed by brush, to be finally stored for air drying. Finally, visual quality control is performed. Attention: the wood surfaces treated with pigmented water-based impregnation naturally tend to gray in a variable period of time depending on the environmental characteristics of the place where the product is installed. This formation of gray patina is a physiological reaction and constitutes a self-protection of wood against atmospheric agents, and does not affect the quality of the product. It is however possible to mitigate the graying of the wood by carrying out a regular renewal with water based impregnating agent.

B. WATER-BASED PAINTING:

The treatment involves a primed coat applied by spraying with catalyzed solvent (160 microns), a drying cycle (4-6 hours) and automatic brushing. Then the water-based paint (200 microns) is sprayed, to be finally stored for air drying. Finally, visual quality control is performed.

Attention: Bellitalia® does not recommend to choose painted wood where it is not possible to carry out a constant maintenance and/or in case of positioning in particularly severe atmospheric conditions (salt area, strong pollution, constant exposure to high solar radiation and high temperatures, etc ...). In these conditions, in fact, the paint layer is destined to degrade quickly, presenting an evident peeling.

A. IMPREGNAZIONE A BASE ACQUA PIGMENTATA:

Il trattamento prevede una spazzolatura automatica del legno, seguita da una mano di impregnante a base acqua pigmentata, applicata a spruzzo e distribuita a pennello, per essere infine stoccata per l'asciugatura all'aria. Alla fine viene eseguito il controllo di qualità visivo.

Attenzione: le superfici in legno trattate con impregnante a base acqua pigmentata tendono naturalmente ad ingrigire in un periodo di tempo variabile a seconda delle caratteristiche ambientali del luogo di installazione del prodotto. Tale formazione di patina grigia è una reazione fisiologica e costituisce un'auto-protezione del legno nei confronti degli agenti atmosferici, e non intacca la qualità del prodotto. E' comunque possibile mitigare l'ingrigimento del legno effettuando un regolare rinnovo con impregnante a base acqua.

B. VERNICIATURA A BASE D'ACQUA:

Il trattamento prevede una mano di fondo applicata a spruzzo con solvente catalizzato (160 micron), un ciclo di asciugatura (4-6 ore) e spazzolatura automatica. Successivamente viene stesa a spruzzo la vernice all'acqua (200 micron), per essere infine stoccata per l'asciugatura all'aria. Alla fine viene eseguito il controllo di qualità visivo.

Attenzione: Bellitalia® sconsiglia di scegliere legno verniciato ove non sia possibile effettuare una manutenzione costante e/o in caso di posizionamento in condizioni atmosferiche particolarmente gravose (area salina, forte inquinamento, esposizione costante a forte irraggiamento solare ed alte temperature, etc...). In tali condizioni, infatti, lo strato di vernice è destinato a degradare velocemente, presentando una sfogliatura evidente.

A- IMPREGNACION A BASE DE AGUA PIGMENTADA

El tratamiento se compone de un espatulado automático de la madera seguido de una mano de imprimación a base de agua pigmentada, aplicada con pulverizador y distribuida con pincel para ser finalmente repartida para su secado en el aire. Posteriormente se verifica con control de calidad a la vista.

Cuidado con la superficie de la madera tratada con imprimación a base de agua pigmentada tienden a manera natural a engrisarse en un periodo de tiempo según las características ambientales del lugar en el que se instala el producto. Esta formación de patina gris es una reacción fisiológica y se constituye como una auto protección de la madera frente a los agentes atmosféricos, y no resta calidad al producto. Es también posible reducir el engrisamiento de la madera efectuando regularmente una nueva aplicación con el mismo sistema.

B- PINTADO A BASE DE AGUA

El tratamiento se compone a base de una mano de fondo aplicada con pulverizador con solvente catalizado (160 micrones) un ciclo de secado de (4-6 horas) espatulado automático. Seguidamente lo mismo con pulverizador barniz al agua (200 microns) para ser finalmente extendido par su secado al aire, posterior se verifica con un control de calidad a la vista.

Atención: Bellitalia® desaconseja escoger madera barnizada donde no sea posible efectuar un mantenimiento constante y en el caso de de una posición y condición atmosférica particularmente extrema (área salina alta polución, exposición constante de fuerte irradiacion solar y altas temperaturas, destinado a degradarse rápidamente, presentando un envejecimiento evidente.

A. PEINTURE À L'EAU COLORÉE :

Le traitement prévoit un brossage automatique, une couche d'imprégnant à l'eau donnée au pistolet avec finition au pinceau. Stockage pour séchage à l'air. Contrôle visuel de la qualité.

Notice: les surfaces en bois traitées à l'eau colorée ont tendance à devenir grises naturellement dans un temps variable selon les caractéristiques environnementales du lieu d'installation. Il s'agit d'une réaction physiologique qui donne aussi une protection automatique au bois contre les agents atmosphériques, sans nuire à la qualité du produit. Il est possible de réduire ce changement de couleur avec un imprégnant à l'eau régulièrement appliqué.

B. PEINTURE À L'EAU :

Le traitement prévoit une couche de fond avec isolant catalysé (160 microns) appliqué au pistolet, le séchage (4-6 heures) et le brossage automatique. Ensuite on applique la peinture à l'eau au pistolet (200 microns) et on laisse sécher à l'air. Contrôle visuel de la qualité.

Notice: Bellitalia® déconseille le bois peint, si l'on n'effectue pas d'entretien régulier et/ou dans des conditions atmosphériques particulièrement difficiles (air marin, très forte pollution, exposition constante aux rayons solaires très forts et aux températures élevées). Dans de telles conditions, en effet, la couche de peinture va vite se dégrader en s'écaillant.

STONEWARE

GRES

GRES

GRÈS



Characteristics: porcelain stoneware is a material that guarantees practicality, resistance and a high aesthetic value, and possesses technical characteristics and colors that remain almost unchanged over time. It is an ingenious material, resistant to thermal changes, hypoallergenic, and easy to clean and sterilize even with environmentally friendly products; it is resistant to mold, to chemical products and to salt corrosion, and also suitable for both normal environmental conditions and environments close to or submerged in water. Bellitalia® opted for this recyclable and environmentally friendly material due to its excellent life cycle and because it has no maintenance costs.

Caratteristiche: il gres porcellanato è un materiale che garantisce praticità, resistenza e un'alta resa estetica presentando caratteristiche tecniche e colori che rimangono pressochè inalterati nel tempo. È un materiale ingelivo, resistente agli sbalzi termici, facile da pulire e sterilizzare anche con prodotti ecologici, ipoallergenico, resistente a muffe, a prodotti chimici e alla corrosione del sale, e inoltre idoneo sia a condizioni ambientali normali che a contesti prossimi all'acqua o sommersi. Riciclabile ed ecologico è stato scelto da Bellitalia® per l'eccellente ciclo di vita e perchè privo di costi di manutenzione.

Características del gres porcelánico es un material que garantiza practicidad ,resistencia y una alto efecto estético presentando características técnicas y colores que permanecen inalterables en el tiempo. Es un material anti heladas resistente a los cambios térmicos, fácil de limpiar y esterilizar también con productos ecológicos hipo alergénico resistente al moho a productos químicos y a la corrosión por la salinidad es además idóneo por las condiciones ambientales normales o entornos próximos al agua o sumergidos. Reciclable y ecológico a sido escogido por Bellitalia® por su excelente ciclo de vida y por bajo coste de mantenimiento.

Le grès cérame porcelainé est une matière pratique, résistante, de bel aspect, dont les couleurs et les caractéristiques techniques ne changent pas au cours du temps. Il ne gèle pas et résiste aux variations thermiques, il se nettoie facilement et peut être désinfecté avec des produits naturels. Antiallergique, résistant à la moisissure, aux produits chimiques et à la corrosion du sel, il s'adapte à toutes les conditions normales ainsi qu'à l'eau de mer. Bellitalia® l'a choisi parce qu'il est recyclable et écologique, durable longtemps et sans nécessité d'entretien.

TIMELINE LA STORIA



BELLITALIA FURNITURE BECOMES WORLD FAMOUS. SO BEGINS EXPORT /
L'ARREDO BELLITALIA DIVENTA FAMOSO NEL MONDO. SI DÀ IL VIA ALL'EXPORT.



THE FIRST LICENSES ARE SOLD FOR KNOW-HOW AND MOULDS IN EUROPE, VENEZUELA, BRAZIL AND TURKEY /
SI VENDONO LE PRIME LICENZE PER KNOW-HOW E STAMPI IN EUROPA, VENEZUELA, BRASILE E TURCHIA.



OUR PRIDE: PRECIOUS STONES LINE IS BORN /
IL FIORE ALL'OCCHIELLO: NASCONO LE PIETRE PREZIOSE.



READY FOR NEW CHALLENGES: THE BIRTH OF THE ORGANIC LINE. COMPLEX SHAPES AND BOLD FINISHING /
LA SFIDA È SEMPRE PIÙ ACCATTIVANTE: NASCE LA LINEA ORGANIC. FORME COMPLESSE E FINITURE AUDACI.



BELLITALIA JOINS THE PLACEMAKERS, GIVING LIFE TO THE BIGGEST INDUSTRIAL GROUP OF URBAN FURNITURE IN THE WORLD /
BELLITALIA ENTRA A FAR PARTE DI THE PLACEMAKERS DANDO VITA AL PIÙ GRANDE GRUPPO INDUSTRIALE DI ARREDO URBANO AL MONDO

1962



BIRTH OF THE COMPANY, A MANUFACTURER OF PRECAST CONCRETE /
NASCITA DELLA SOCIETÀ, PRODUTTRICE DI PREFABBRICATI IN CEMENTO.

1988

1986



THE CONCEPT OF STREET FURNITURE IS BORN, ALONG WITH THE CLASSIC LINE /
NASCE IL CONCETTO DI ARREDO URBANO, NASCE LA LINEA CLASSICA.

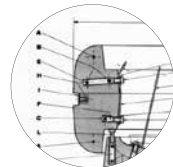

REGISTRATION OF THE FIRST PATENTS /
REGISTRAZIONE DEI PRIMI BREVETTI INDUSTRIALI.

2000



THE FURNITURE RANGE IS COMPLETED WITH THE METAL LINES MADE OF CAST IRON AND STEEL /
LA GAMMA ARREDO SI COMPLETA CON LE LINEE METAL IN GHISA E ACCIAIO.

2003

2006



PRODUCED THE FIRST LITTER BIN ATLANTE. NOW HEADING TOWARDS 18,000 UNITS SOLD /
VIENE PRODOTTO IL PRIMO CESTONE ATLANTE. RAGGIUNGERÀ I 18.000 PEZZI VENDUTI.

2013



AN EXTRAORDINARY INVENTION: ULTRATENSE CONCRETE®. HIGH-TECH CEMENT AT THE HIGHEST DEGREE OF EVOLUTION /
UNA STRAORDINARIA INVENZIONE: L'ULTRATENSE CONCRETE®. IL CEMENTO HIGH-TECH AL MASSIMO GRADO DI EVOLUZIONE.

2018

BELLITALIA IS

more than **50 years** of concrete processing
oltre 50 anni di esperienza

100% recyclable
100 % riciclabile

17 internal custom
1 dogana interna
marmi italiani utilizzati
italian marbles used

4 rotating cranes
4 gru girevoli

12 finishing positions
12 stazioni di finitura

20 different combinations of aggregates
20 diverse combinazioni di aggregati

8 overhead cranes
8 carriponte

6 concrete mixing plants
6 impianti di betonaggio

over **500** production molds
oltre 500 stampi

50.000 square meters of surface
50.000 mq di superficie
lavoriamo più
we work more than

450 m² of surfaces every day
450 m² di superficie ogni giorno

20 different mixtures of production
20 miscele di produzione

...molds whose weight is over **6.000 kg**
...stampi il cui peso è oltre 6.000 kg



FACTORY & HEADQUARTER

Ponte nelle Alpi, BL - Italy

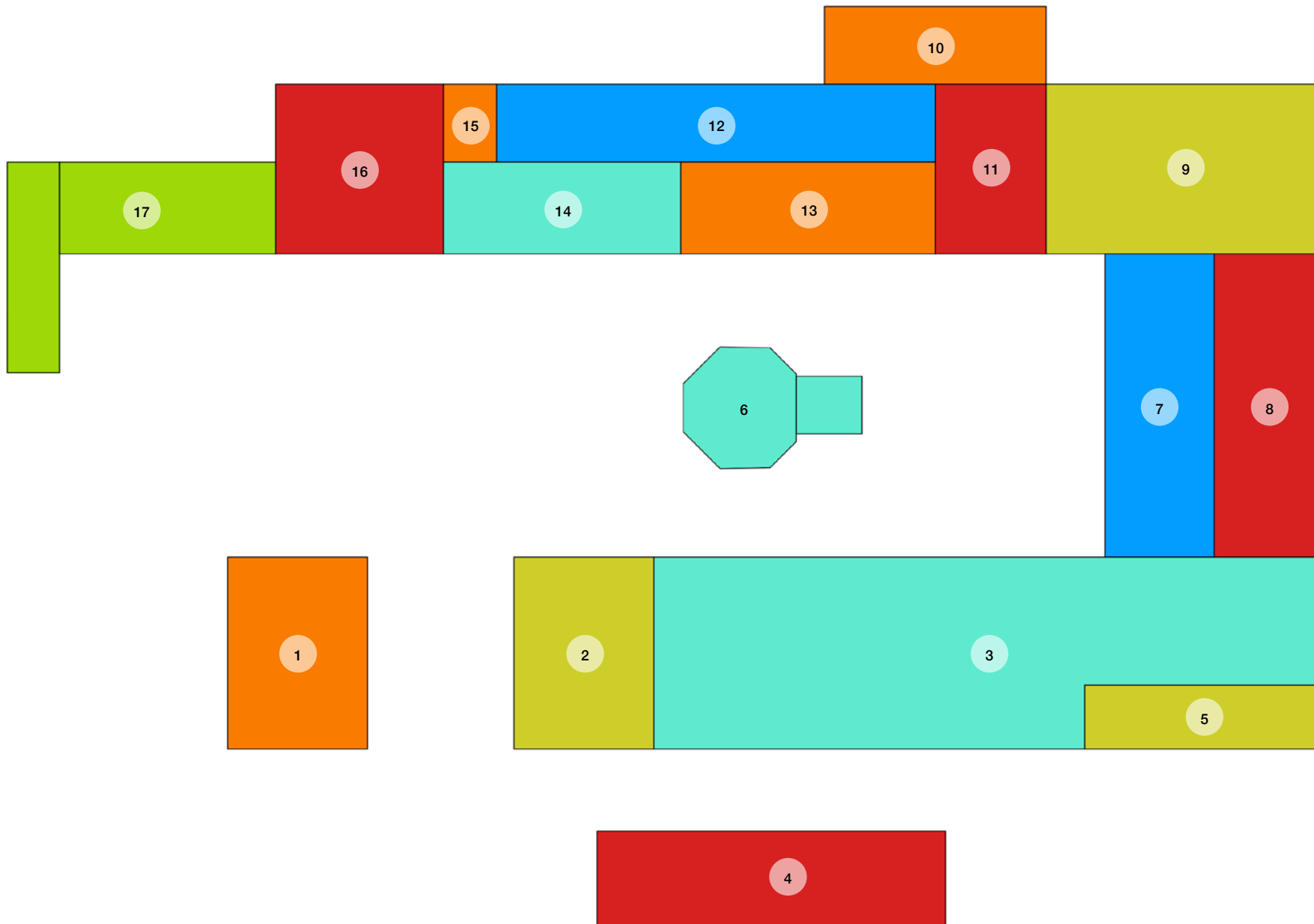

LEGEND LEGENDA

- 1 LOADING/UNLOADING AREA
AREA CARICO/SCARICO
- 2 PRECIOUS STONES CASTING PLANT
IMPIANTO GETTI PIETRE PREZIOSE
- 3 MOULDS MANAGEMENT AND DEMOULDING PHASE
GESTIONE STAMPI E SMODELLAZIONE
- 4 MOULDS WAREHOUSE
MAGAZZINO STAMPI
- 5 WHITE GRANITE CASTING PLANT
IMPIANTO GETTI DI GRANITO BIANCO
- 6 WHITE GRANITE CASTING PLANT
IMPIANTO GETTI DI GRANITO BIANCO
- 7 SANDBLASTING AND BUSH HAMMERED PLANT
IMPIANTO DI SABBIAURA E BOCCIARDATURA
- 8 BUFFERING
BUFFERING
- 9 POLISHING PLANT
IMPIANTO DI LEVIGATURA
- 10 BUFFERING
BUFFERING
- 11 VARNISHING CABIN
CABINE VERNICIATURA
- 12 UTC® PRODUCTION PLANT
IMPIANTO DI PRODUZIONE UTC®
- 13 PLANT MAINTENANCE WORKSHOP
OFFICINA MANUTENZIONE IMPIANTI
- 14 MOULDS MAINTENANCE WORKSHOP AND PRODUCTION OF
REINFORCEMENTS
OFFICINA MANUTENZIONE SAMPI E COSTRUZIONE ARMATURE
- 15 REPORTS AND TESTS LABORATORY
LABORATORIO ANALISI E PROVE
- 16 TOOLS AND COMPONENTS WAREHOUSE
MAGAZZINO ACCESSORI E COMPONENTI
- 17 MANAGEMENT AND OFFICES
DIREZIONE UFFICI



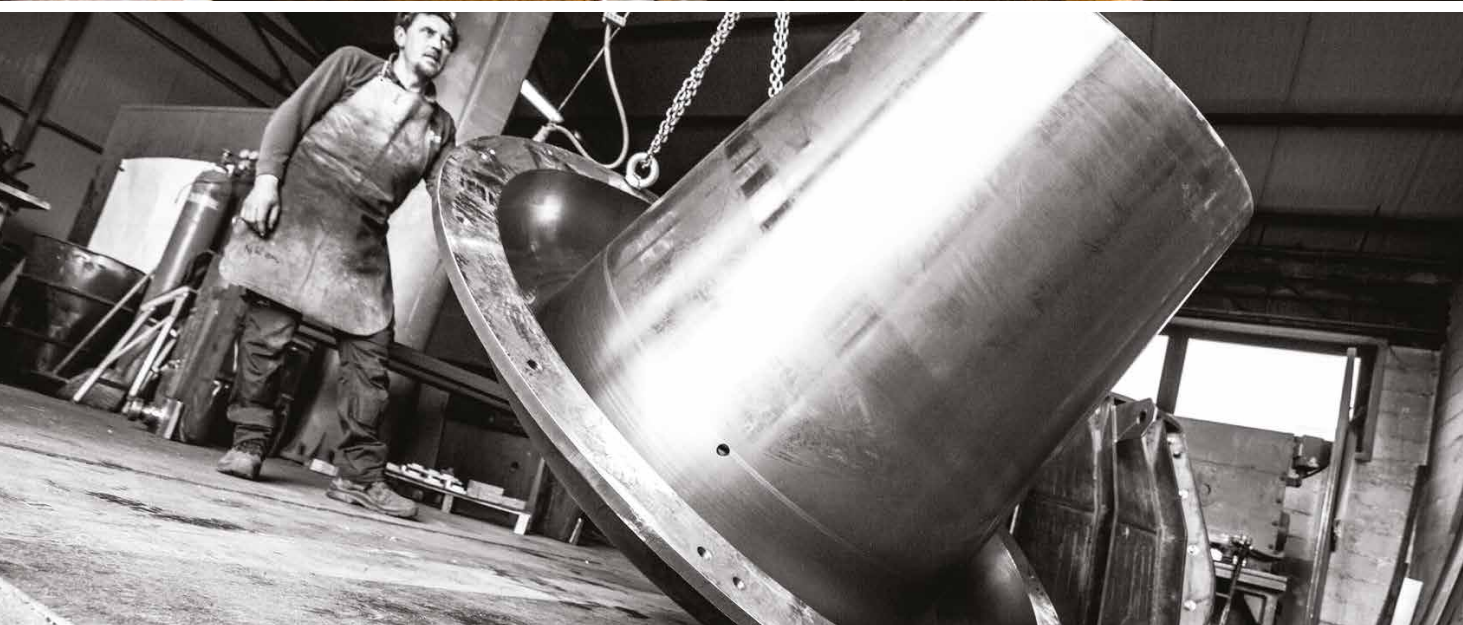

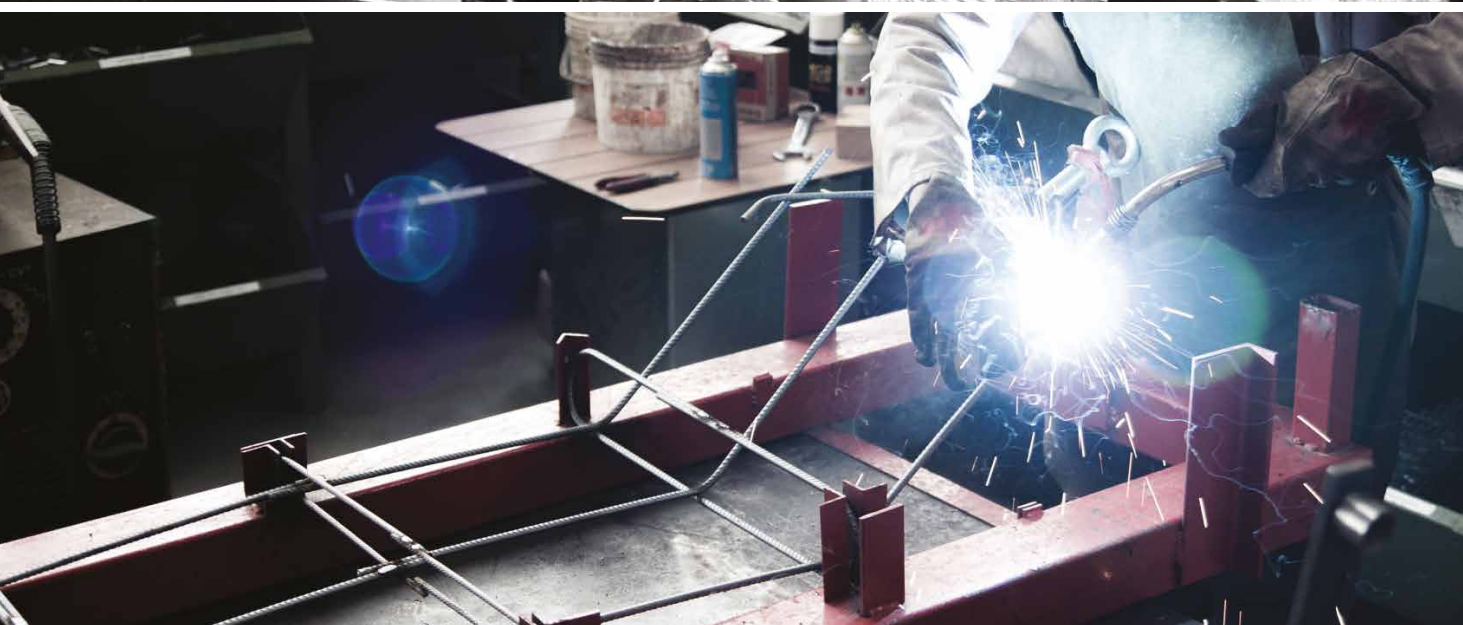



CERTIFICATIONS CERTIFICAZIONI

CERTIFICATIONS CERTIFICAZIONI

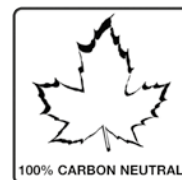

DUNS NUMBER 428735856

UNI EN ISO 9001:2015
(ISO 9001:2015)

15886/16/00

2015-SKM-PEFC-121

FSC-STD-40-004 VER2.1,

100% CARBON NEUTRAL

EN ISO 2409:2016

ASTM F735-11
EN ISO 2813:2014

ASTM 5388

ASTM C 1585-13

EN ISO 15184:2012

EN ISO 2813:2014

EN ISO 12390-7:2009

EN ISO 12390-13:2012

EN ISO 12390-8:2009

EN ISO 720 HOURS
120 CYCLES
+ 80 ° - 30 °
720 ORE
120 CICLI
+ 80° - 30°

EN ISO TEST OF
RESILIENCE
PROVA DI
RESILIENZA

QUADRATURE TEST
TEST DI QUADRATURA

ABRASION TEST
TEST DI ABRASIONE

ACCELERATED AGING AWT FOR 720 HOURS
INVECCHIAMENTO ACCELERATO AWT PER 720 ORE

WATER ABSORPTION SPEED
VELOCITÀ ASSORBIMENTO DELL'ACQUA

HARDNESS OF COATINGS
DUREZZA DEI RIVESTIMENTI

SURFACE GLOSS AT 20 AND 60 DEGRESS (GLOSS
VALUE)
BRILLANTEZZA DELLA SUPERFICIE A 20 E 60 GRADI
(GLOSS VALUE)

CONCRETE DENSITY
DENSITÀ CALCESTRUZZO

ELASTIC MODULE
MODULO ELASTICO

DETERMINATION OF PENETRATION DEPTH UNDER
PRESSURE
DETERMINAZIONE PROFONDITÀ DI PENETRAZIONE
SOTTO PRESSIONE

TERMAL SHOCK
SHOCK TERMICO

IMPACT TEST WITH SPHERICAL WEIGHING
OF ABOUT 600 G
PROVA DI IMPASTO CON PESA DA CIRCA
600 GR SFERICO

Concept:
Marina Tasca

Foto:
Archivio Bellitalia® / Bellitalia® Archive
Francesco Vascellari
Marina Tasca
Nicole Struppert
Jorge Moro
Pietro Savorelli
Per Kårehed

© Tutti i diritti riservati.
È vietata la riproduzione anche parziale di immagini e testi.
© All rights reserved.
The reproduction of images, drawings and texts, even if partial, is forbidden.

Finito di stampare nel mese di Gennaio 2019
Prima edizione

Printed in January 2019
First Editon

Bellitalia® Srl si riserva di apportare ai propri prodotti qualsiasi modifica ritenuta utile al miglioramento qualitativo degli stessi, sia dimensionale che strutturale.
Foto, disegni e testi non hanno carattere contrattuale.

Bellitalia® Srl reserves the right to modify the dimensions and structure of its products at any time without prior notice in order to improve quality and durability.
Photo, drawings and texts are not contractual.

Le immagini contenute in questo catalogo hanno solo scopo illustrativo, per alcuni prodotti abbiamo utilizzato visualizzazioni.

The images contains in this catalogue are for illustrative purposes only, for some products we used visualizations.

Per eventuali modifiche o aggiornamenti, fare riferimento al sito web: www.bellitalia.net

For possible modifications or updates, please refer to the web site: www.bellitalia.net